

**TECHNICAL MANUAL  
OPERATORS MANUAL  
FOR**

**NIGHT VISION SIGHT SET, INFRARED AN/UAS-11  
(NSN 5855-01-083-9051)**

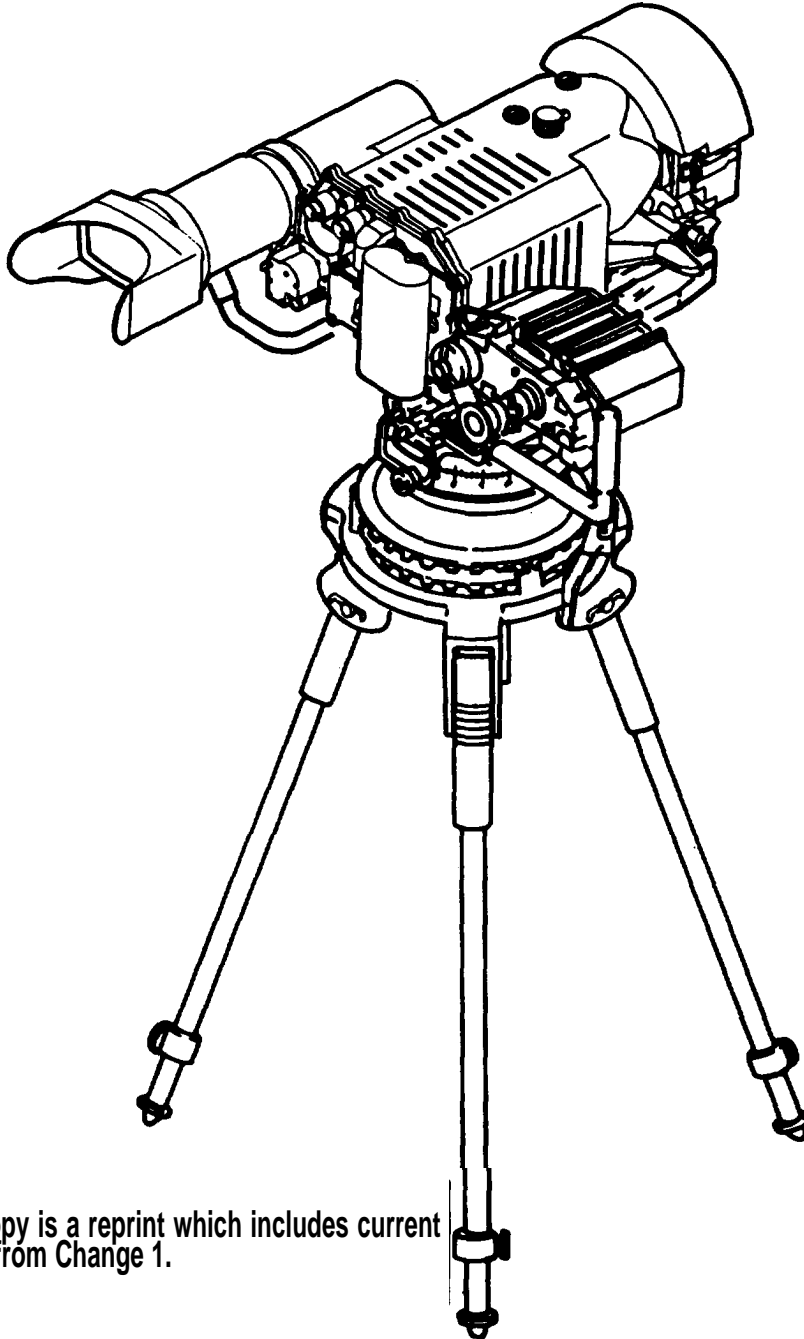

This copy is a reprint which includes current pages from Change 1.

**HEADWAITERS, DEPARTMENT OF THE ARMY  
21 NOVEMBER 1985**

<b>HOW TO USE THIS MANUAL</b>	<b>III</b>
-------------------------------	------------

<b>CHAPTER 1</b>	
<b>INTRODUCTION</b>	<b>1-1</b>

<b>CHAPTER 2</b>	
<b>OPERATING INSTRUCTIONS</b>	<b>2-1</b>

<b>CHAPTER 3</b>	
<b>NIGHT SIGHT MAINTENANCE INSTRUCTIONS</b>	<b>3-1</b>

<b>APPENDIX A</b>	
<b>REFERENCES</b>	<b>A-1</b>

<b>APPENDIX B</b>	
<b>COMPONENTS OF END ITEM AND BASIC ISSUE ITEMS LISTS</b>	<b>B-1</b>

<b>APPENDIX C</b>	
<b>ADDITIONAL AUTHORIZATION LIST</b>	<b>C-1</b>

<b>APPENDIX D</b>	
<b>EXPENDABLE SUPPLIES AND MATERIALS LISTS</b>	<b>D-1</b>

<b>INDEX</b>	<b>INDEX-1</b>
--------------	----------------

Change

No. 2

HEADQUARTERS  
DEPARTMENT OF THE ARMY  
Washington, D.C., 5 June 1992

**OPERATOR'S MANUAL  
FOR  
NIGHT VISION SIGHT SET,  
INFRARED, AN/UAS-11  
(NSN 5855-01-083-9051)**

TM9-5855-253-10, 21 November 1985, is changed as follows:

1. Remove old pages and insert new pages as indicated below.
2. New or changed material is indicated by a vertical bar in the margin of the page.
3. Added or revised illustrations are indicated by a miniature pointing hand, or vertical bar.

Remove Pages

A (B blank)  
i and ii  
2-19 and 2-20  
2-23 and 2-24  
B-1 through B-5 (B-6 blank)  
C-1 (C-2 blank)  
D-1 and D-2

Insert Pages

A (B blank)  
i and ii  
2-19 and 2-20  
2-23 and 2-24  
B-1 through B-5 (B-6 blank)  
C-1 (C-2 blank)  
D-1 and D-2

4. File this change sheet in front of the publication for reference purposes.

By Order of the Secretary of the Army:

Official

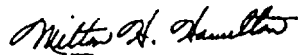

MILTON H. HAMILTON  
*Administrative Assistant to the  
Secretary of the Army*

01949

GORDON R. SULLIVAN  
*General, United States Army  
Chief of Staff*

Distribution:

To be distributed in accordance with DA Form 21-32-E, Block 1489, requirements for TM 9-5855-253-10.



Remove power before removing and replacing any assembly, subassembly, or component. HIGH VOLTAGE is used in this system. Death or injury can result if you do not observe safety precautions.

## **WARNING**

### **RADIATION HAZARD**



The antireflective coating on all infrared optics contains slightly radioactive thorium fluoride. Potential hazard may result from ingestion (swallowing or inhaling) of this coating material. Dispose of broken lenses and optics in accordance with AR 385-11.



Chemical agent resistant coating (CARC) is extremely toxic and flammable. Never use where sparks, smoking or open flame may be present. CARC, if improperly used, may cause long term health problems. Avoid contact with skin, breathing of fumes, or ingestion of dried particles. Use must be monitored by the local safety office and preventive medicine support activity. Refer to TM 43-0139 for applicable safety precautions prior to removal or application of CARC.

**LIST OF EFFECTIVE PAGES**

INSERT LATEST CHANGED PAGES. DESTROY SUPERSEDED PAGES.

NOTE: The portion of the text affected by the changes is indicated by a vertical line in the outer margins of the page. Changes to illustrations are indicated by miniature pointing hands. Changes to wiring diagrams are indicated by shaded areas.

Dates of issue for original and change pages are:

Original.....0..... 21 Nov 1985  
 Change . . . . .1..... 22 Apr 1988  
 Change . . . . .2..... 5 June 1992

TOTAL NUMBER OF PAGES IN THIS PUBLICATION IS 130 CONSISTING OF THE FOLLOWING:

Page No.	*Change No.	Page No.	*Change No.	Page No.	*Change No.
A	2	D-1	0		
B blank	2	D-2	2		
a	1	Index-1	0		
b blank	1	Index-2	1		
i	2				
ii thru iv	0				
1-1 thru 1-9	0				
1-10	1				
1-11 thru 1-16	0				
2-1	1				
2-2 thru 2-5	0				
2-6	1				
2-7 thru 2-14	0				
2-15	1				
2-16 thru 2-18	0				
2-19, 2-20	2				
2-21 thru 2-23	0				
2-24	2				
2-25 thru 2-35	0				
2-36	1				
2-37, 2-38	0				
2-39 thru 2-41	1				
2-42, 2-43	0				
2-44	1				
2-45 thru 2-48	0				
2-49	1				
2-50 thru 2-74	0				
3-1 thru 3-7	0				
3-8	1				
3-9 thru 3-14	0				
3-15	1				
3-16 blank	1				
A-1	1				
A-2 blank	1				
B-1	0				
B-2 thru B-5	2				
B-6 blank	2				
C-1	2				
C-2 blank	2				

\*Zero in this column indicates an original page.

**OPERATOR'S MANUAL  
 FOR  
 NIGHT VISION SIGHT SET,  
 INFRARED AN/UAS-11  
 (NSN 5855-01-083-9051)**

**REPORTING ERRORS AND RECOMMENDING IMPROVEMENTS**

You can help improve this manual. If you find any mistakes, or if you know of a way to improve the procedures, please let us know. Mail your letter, DA Form 2028 (Recommended Changes to Publications and Blank Forms), or DA Form 2028-2 located in the back of this manual, direct to: Commander, U.S. Army Missile Command, ATTN: AMSMI-MMC-ME-P, Redstone Arsenal, AL 35898-5238. A reply will be furnished to you.

		Page
	HOW TO USE THIS MANUAL . . . . .	iii
CHAPTER 1	INTRODUCTION . . . . .	1-1
Section I	General Information . . . . .	1-1
Section II	Equipment Description and Data... . . . .	1-6
Section III	Functional Description . . . . .	1-16
CHAPTER 2	OPERATING INSTRUCTIONS . . . . .	2-1
Section I	Description and Use of Operator's Controls and Indicators . . . . .	2-1
Section II	Preventive Maintenance Checks and Services . . . . .	2-10
Section III	Emplacement of Night Sight . . . . .	2-25
Section IV	Operation Under Usual Conditions . . . . .	2-44
Section V	Operation Under Unusual Conditions . . . . .	2-58
Section VI	Component Stowage and Transportation Data. . . . .	2-65
CHAPTER 3	NIGHT SIGHT MAINTENANCE INSTRUCTIONS . . . . .	3-1
Section I	Night Sight Troubleshooting Procedures . . . . .	3-1
Section II	Maintenance Procedures . . . . .	3-8

APPENDIX A	REFERENCES . . . . .	A-1
APPENDIX B	COMPONENTS OF END ITEM AND BASIC ISSUE ITEMS LISTS . .	B-1
APPENDIX C	ADDITIONAL AUTHORIZATION LIST . . . . .	C-1
APPENDIX D	EXPENDABLE SUPPLIES AND MATERIALS LIST . . . . .	D-1
	INDEX . . . . .	INDEX-1

## HOW TO USE THIS MANUAL

1. Take a few minutes to look through this manual. We've designed this manual so that it will be easy for you to find and perform the procedures you need.
2. If the Night Sight needs repair and you know what's wrong with it, here's what you do:
  - a) Turn to the index and check for a paragraph on the component you want to remove and replace.
  - b) Turn to the paragraph. Under the paragraph title, you'll find the tools, materials, and equipment condition needed to perform the procedure. If there are no tools or materials needed, it will also be noted here. If you have more than one of a specific type of tool (for example, two different screwdrivers) the text will indicate which tool to use in the necessary steps. If there is no equipment condition needed to prepare the Night Sight for removal procedure, it will be noted that the Night Sight is assembled.
  - c) To remove the bad component, perform the removal procedure.
  - d) To install the new component, perform the replacement procedure. The Night Sight should now be ready to operate.
  - e) Perform the troubleshooting procedure paragraph 3-2 to verify repair of the Night Sight.
3. If the Night Sight needs repair and you don't know what's wrong with it, you go to the troubleshooting procedures. Troubleshooting procedures are written in the flow chart style. Each set of instructions is written in a box and the boxes are connected by arrows. By following the arrows, you can work your way through the procedure. The chart on the following page tells you what the various boxes mean.

### HOW TO USE THIS MANUAL (CONT)

3. (Cont)

Beginning and end of procedure.

Do instruction before looking for an indication.

Look for a YES or NO indication. For a NO indication, go to corrective action block.

Do steps following YES indication.

Go to next page and continue the procedure.

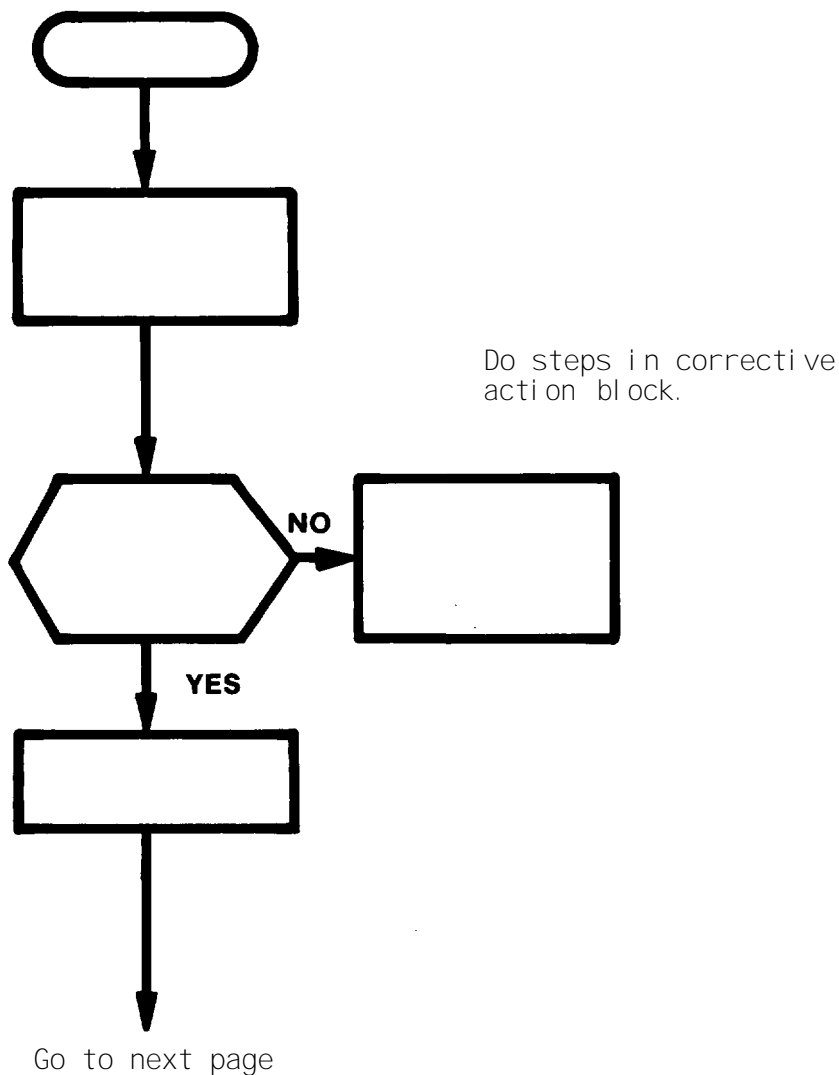

After performing a step in a corrective action block, return to the beginning of the procedure and perform the procedure again. If you branch into the same corrective action block, perform the second step, and so on. The troubleshooting procedure has been successfully performed when you go from START to END OF TASK without branching into a corrective action block.



## CHAPTER 1

### INTRODUCTION

#### CHAPTER OVERVIEW

This chapter is an introduction to the Night Vision Sight Set, Infrared AN/UAS-11 (AN/UAS-11 Equipment Set). The chapter is divided into three sections. Section I contains general information on the AN/UAS-11 Equipment Set. Section II gives a description and data for the AN/UAS-11 Equipment Set and lists equipment used with the AN/UAS-11 Equipment Set. Section III contains the functional description of the AN/UAS-11 Equipment Set.

CHAPTER CONTENTS	PAGE
Section I. GENERAL INFORMATION	1-1
Section II. EQUIPMENT DESCRIPTION AND DATA	1-6
Section III. FUNCTIONAL DESCRIPTION	1-16

#### Section I. GENERAL INFORMATION

SECTION CONTENTS	PARA	PAGE
SCOPE	1-1	1-2
MAINTENANCE FORMS, RECORDS, AND REPORTS	1-2	1-4
REPORTING EQUIPMENT IMPROVEMENT RECOMMENDATIONS (EIRS)	1-3	1-4
NOMENCLATURE CROSS-REFERENCE LIST	1-4	1-5
LIST OF ABBREVIATIONS	1-5	1-6

## 1-1 SCOPE

This manual is for your use in operating and maintaining AN/UAS-11 Equipment Set, which consists of the following major items. All component items are shown in Components of End Item and Basic Issue Items Lists, Appendix B.

- a. Night Vision Sight, Infrared AN/TAS-6

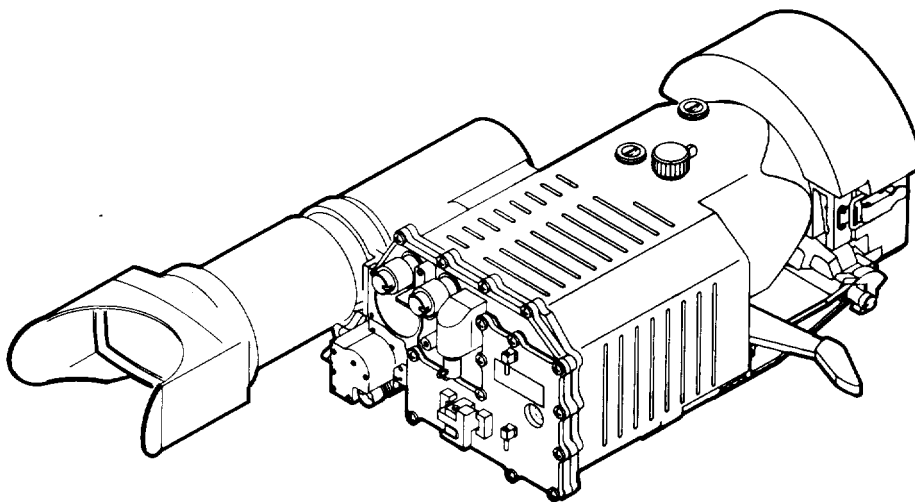

- b. Mount Assembly, Armored Personnel Carrier

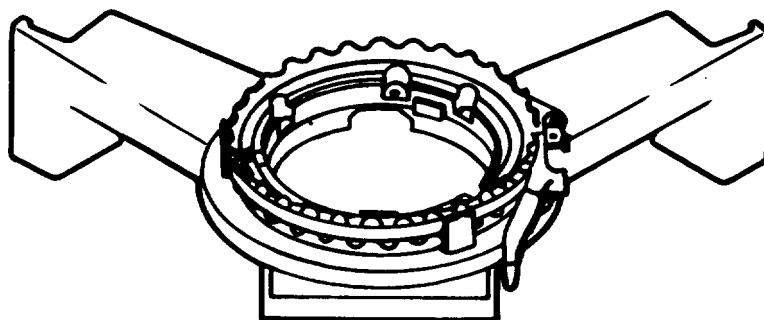

c. Tripod, Night Vision Sight

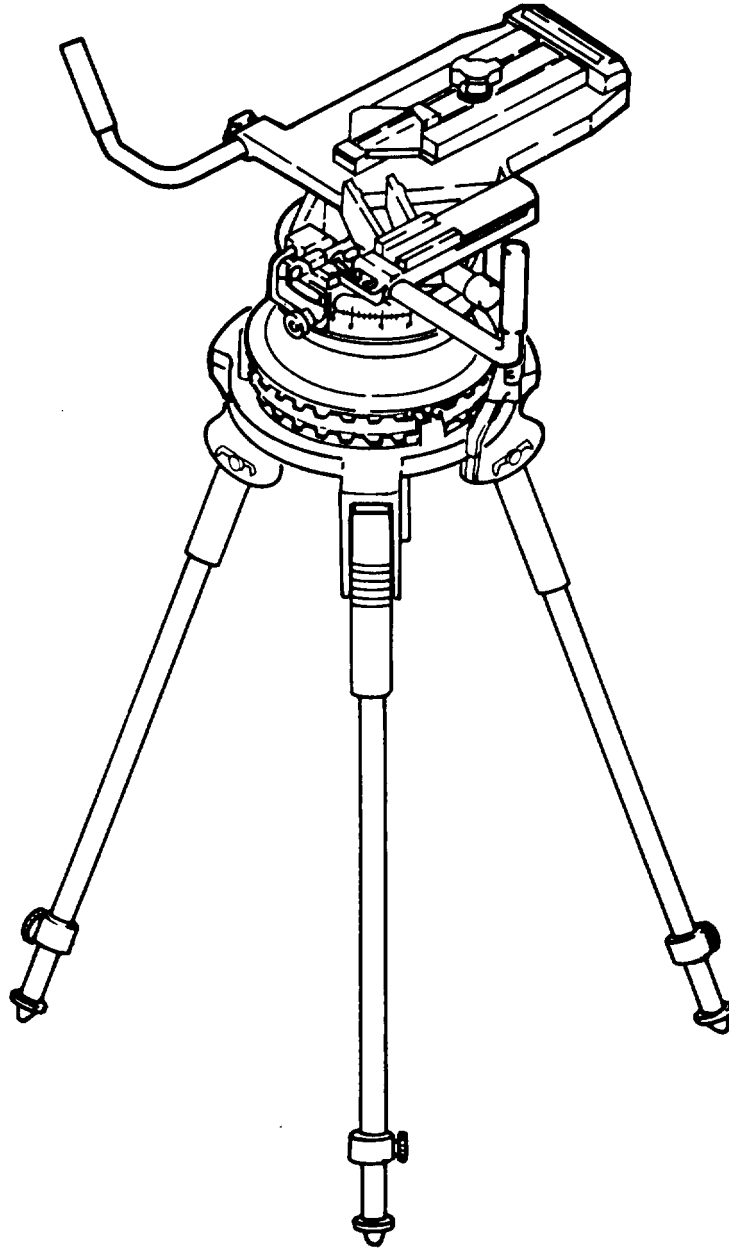

d. Collimator, Boresight SU-93/TAS or Collimator, Boresight SU-93A/TAS

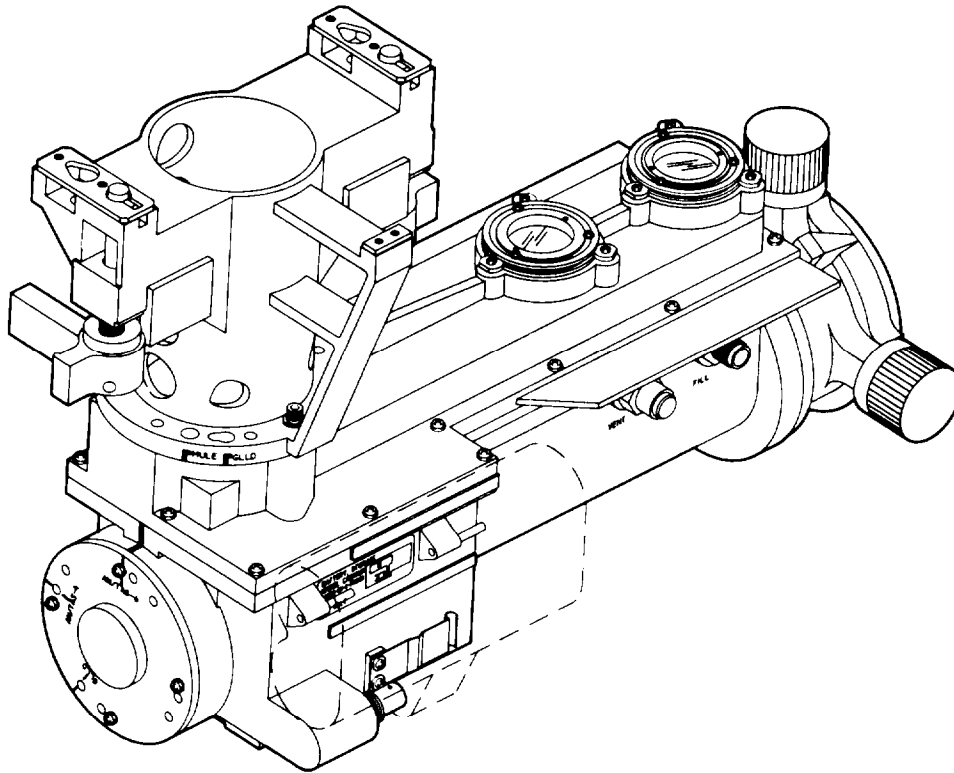

## **1-2. MAINTENANCE FORMS, RECORDS, AND REPORTS**

Department of the Army forms and procedures used for equipment maintenance will be those prescribed by DA PAM 738-750, The Army Maintenance Management System (TAMMS).

## **1-3. REPORTING EQUIPMENT IMPROVEMENT RECOMMENDATIONS (EIRs)**

If your equipment needs improvement, let us know. Send us an EIR. You, the user, are the only one who can tell us what you don't like about your equipment. Let us know why you don't like the design, put it on an SF 368 (Quality Deficiency Report). Mail it to us at Commander, U.S. Army Missile Command, ATTN: AMSMI-QMD, Redstone Arsenal, AL 35898-5290. We'll send you a reply.

**1-4. NOMENCLATURE CROSS-REFERENCE LIST**

Official nomenclature for items and parts of Night Vision Sight Set, Infrared AN/UAS-11 is listed in the Repair Parts and Special Tools List (RPSTL), TM 9-5855-247-24P-2. The following cross-reference covers those items having common names that differ from the official nomenclature.

TM NOMENCLATURE	OFFICIAL NOMENCLATURE
AN/GVS-5	Laser Infrared Observation Set AN/GVS-5
AN/UAS-11 Equipment Set	Night Vision Sight Set, Infrared AN/UAS-11
APC Mount Assembly	Mount Assembly, Armored Personnel Carrier
Battery	Battery Assembly
Boresight Collimator	Collimator, Boresight SU-93A/TAS, or Collimator, Boresight SU-93/TAS
Boresight Collimator Carrying Case	Case, Carrying, Collimator, Boresight
Carrying Bag	Bag, Carrying
Cleaning Kit	Kit, Lens Cleaning
Cleaning Kit Bag	Bag, Press Seal
Coolant Cartridge	Cartridge, Coolant
Equipment Cover	Cover, Equipment
Night Sight	Night Vision Sight, Infrared AN/TAS-6
Night Sight Field Handling Case	Case, Handling, Field
Power Cables	Cables, Power
Tri pod	Tri pod, Night Vision Sight

**1-5. LIST OF ABBREVIATIONS**

A list of abbreviations used in this manual and their definitions are listed below.

<u>Abbreviation</u>	<u>Definition</u>
APC	Armored Personnel Carrier
AZ	Azimuth
BRT	Brightness
CB1	Circuit Breaker No. 1
CTRS	Contrast
EL	Elevation
GLLD	Guidance Laser Locator and Designator
IR	Infrared
NFOV	Narrow field-of-view
NODLR	Night Observation Device Long Range
PMCS	Preventive Maintenance Checks and Services
TOW	Tube-Launched, Optically-Tracked, Wire-Command-Link
WFOV	Wide field-of-view

**Section II. EQUIPMENT DESCRIPTION AND DATA**

<u>SECTION CONTENTS</u>	PARA	PAGE
SCOPE	1-6	1-6
EQUIPMENT CHARACTERISTICS, CAPABILITIES, AND FEATURES	1-7	1-7
SYSTEM CHARACTERISTICS	1-8	1-14
SUPPORT EQUIPMENT	1-9	1-15

**1-6. SCOPE**

This section describes the equipment characteristics, capabilities, features, differences, and other data.

## 1-7. EQUIPMENT CHARACTERISTICS, CAPABILITIES, AND FEATURES

- a. Night Vision Sight, Infrared AN/TAS-6.

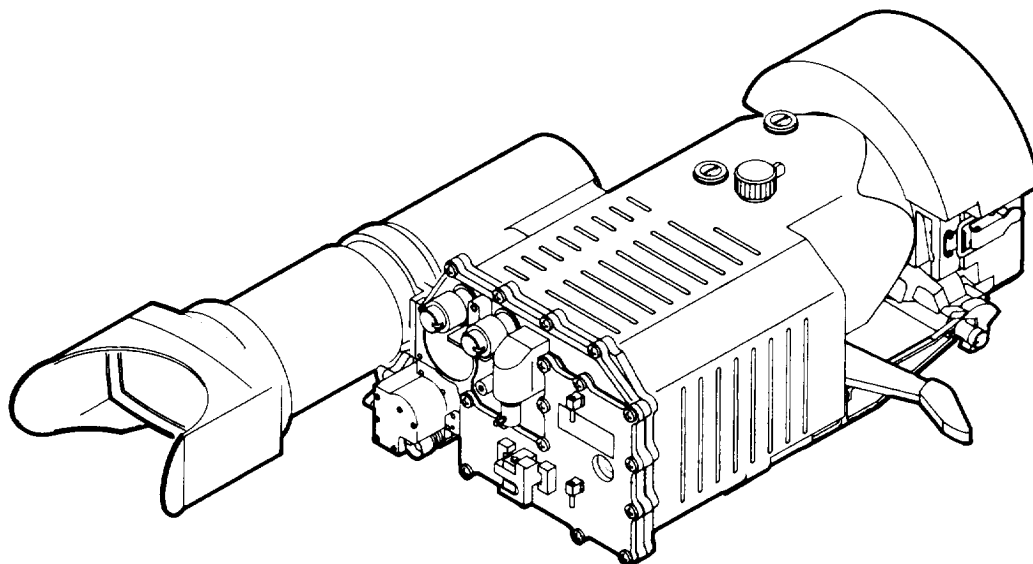

The Night Vision Sight, Infrared AN/TAS-6 (Night Sight) is a self-contained infrared system. The Night Sight enables the operator to track targets in darkness, daylight, and degraded field conditions. The Night Sight is cooled by a rechargeable coolant cartridge and is powered by a vehicle power conditioner or an attached rechargeable battery. Infrared energy entering the front lens of the Night Sight is converted to visible light which may be viewed through a binocular eyepiece at the rear of the Night Sight. A wide field-of-view (WFOV) or narrow field-of-view (NFOV) may be selected, depending on target distance.

1-7. EQUIPMENT CHARACTERISTICS, CAPABILITIES, AND FEATURES (CONT)

b. Boresight Collimator.

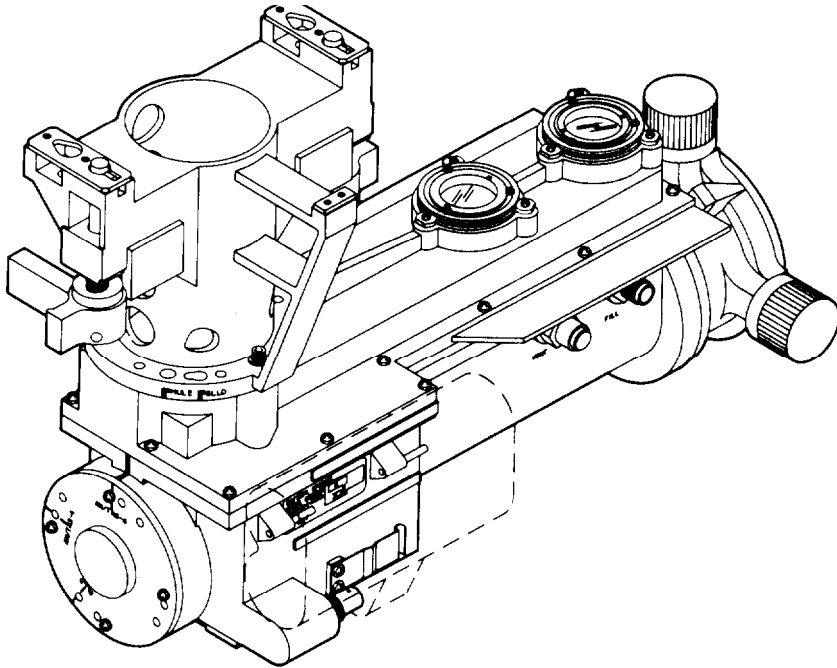

The Boresight Collimator is used to align the Night Sight with the AN/GVS-5. It latches easily to the Night Sight and operates from battery power. Insure that Boresight Collimator is in the AN/TAS-6 position. If it is not, refer to next higher level of maintenance.

c. Traverse Head Assembly.

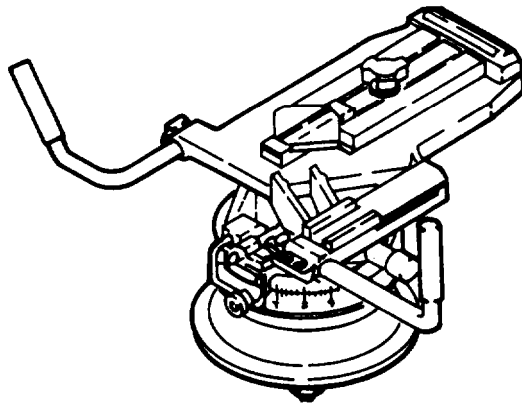

The traverse head assembly enables the operator to mount the Night Sight to the Tripod or to the APC Mount Assembly. The traverse head assembly is used to move the Night Sight in azimuth and elevation.



**1-7. EQUIPMENT CHARACTERISTICS, CAPABILITIES, AND FEATURES (CONT)**

d. Leg Assembly.

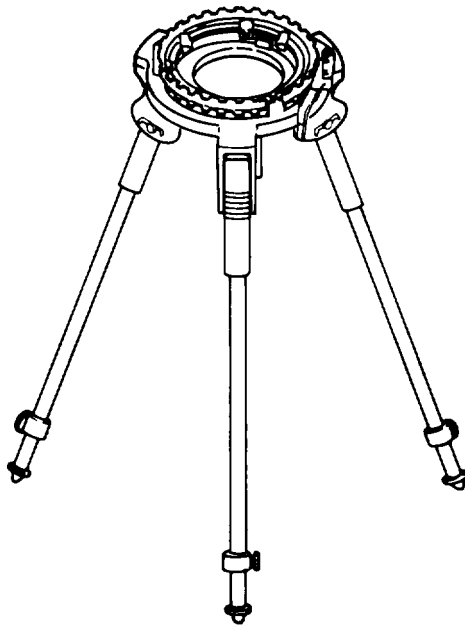

The leg assembly enables the operator to use the Night Sight in a ground-mounted configuration.

e. APC Mount Assembly.

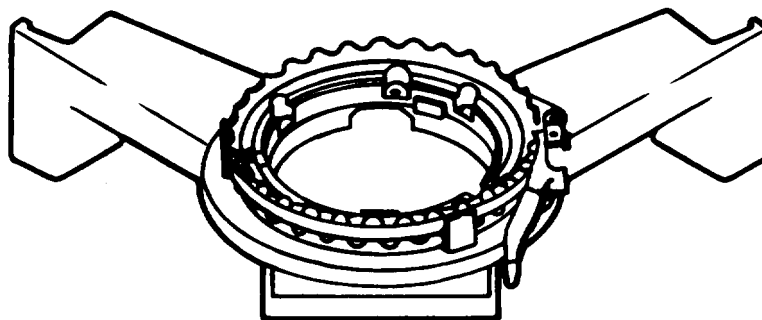

The APC Mount Assembly allows the operator to mount the Night Sight on the APC.

1-7. EQUIPMENT CHARACTERISTICS, CAPABILITIES, AND FEATURES A(CONT)

f. Boresight Collimator Case.

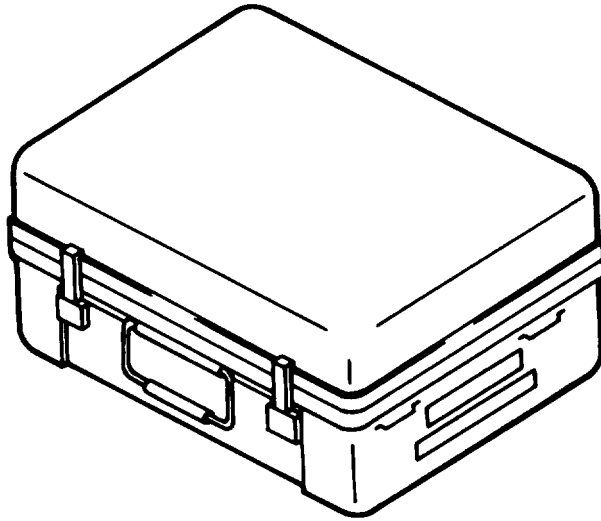

The Boresight Collimator case is used to store the Boresight Collimator.

g. Night Sight Field Handling Case.

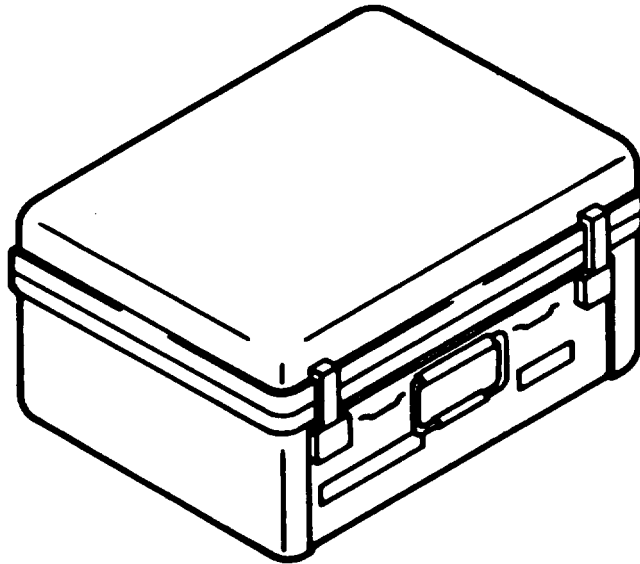

The Night Sight field handling case is used to store the Night Sight.

**1-7. EQUIPMENT CHARACTERISTICS, CAPABILITIES, AND FEATURES (CONT)**

h. Equipment Cover.

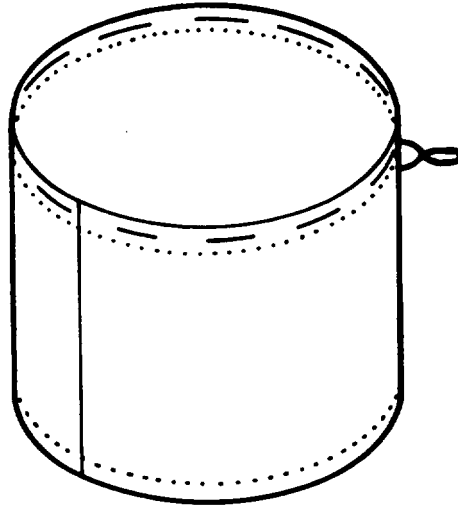

The equipment cover is used to protect the Night Sight during bad weather and limited travel.

i. Arctic Kit.

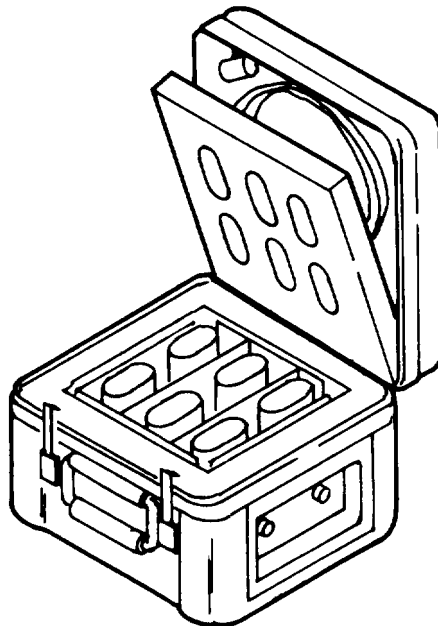

The Arctic Kit is used to warm batteries, thereby increasing battery operating time. The Arctic Kit consists of an insulated carrying case, six chemical heating pads, and a power cable to connect the kit to the Night Sight.

1-7. EQUIPMENT CHARACTERISTICS, CAPABILITIES, AND FEATURES (CONT)

j. Vehicle Power Conditioner.

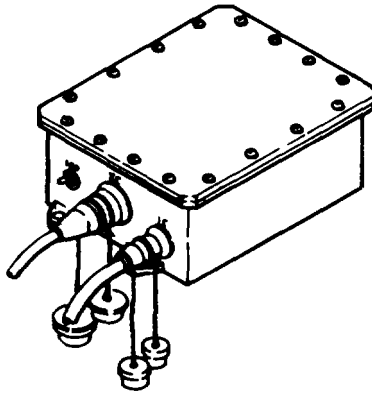

The vehicle power conditioner provides power to the Night Sight from the vehicle power system.

k. Tripod Carrying Bag.

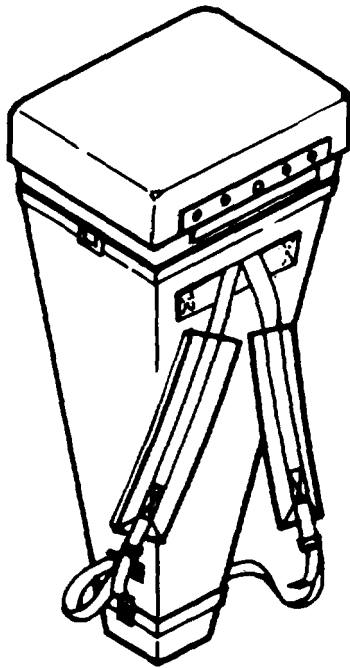

The Tripod carrying bag is used to store the Tripod and traverse head assembly.

## 1-7. EQUIPMENT CHARACTERISTICS, CAPABILITIES, AND FEATURES (CONT)

### 1. Battery Case.

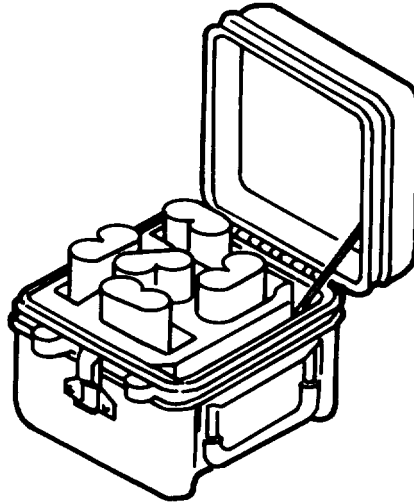

The battery case is used to store batteries.

### m. Coolant Cartridge Case.

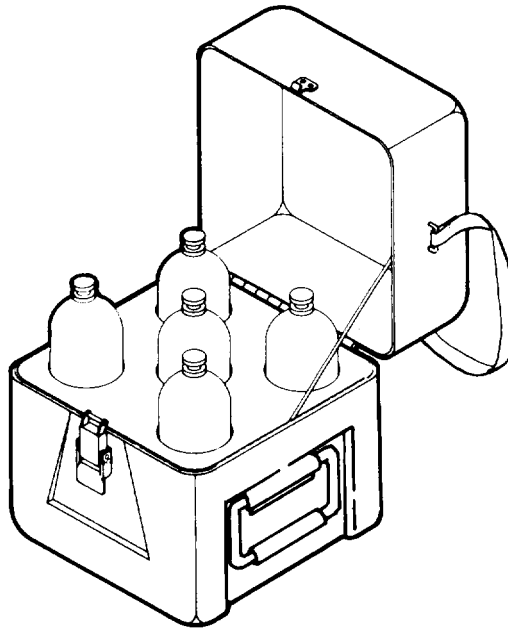

The coolant cartridge case is used to store coolant cartridges.

**1-7. EQUIPMENT CHARACTERISTICS, CAPABILITIES, AND FEATURES (CONT)**

n. Lens Cleaning Kit and 0.050 Inch Socket-Head Screw Key.

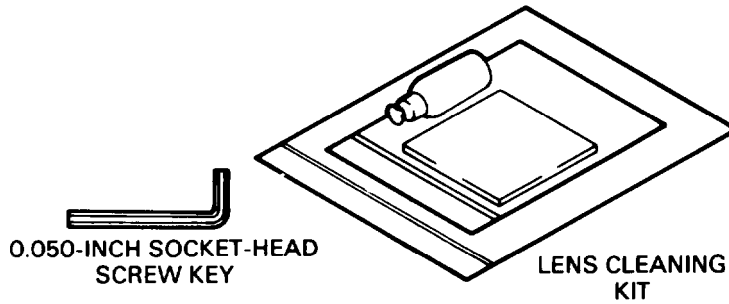

The lens cleaning kit is used to clean the Night Sight Lenses. The 0.050-inch socket-head screw key is used for removal of the Night Sight eyeshield.

**1-8. SYSTEM CHARACTERISTICS**

Electrical power source	Vehicle Power Conditioner or attached rechargeable battery
Voltage required	4.6 to 5.0 volts dc
Input illumination	Infrared
Magnification	X3 X9
Field of view	3.3 by 6.6 degrees 1.1 by 2.2 degrees
WFOV	2.0 hours minimum at -5°F (-2.06°C) to +125°F (+51.7°C)
NFOV	1.0 hour minimum at -25°F (-31.7°C)
Battery operating time per recharge	
Coolant cartridge	
Pressure range	6000 to 1000 psi
Operating time per recharge	2.0 hours minimum at +125°F (+51°C)
Cooldown time	15 seconds or less (at 6000 psi)
Operational temperature range	-40°F (-40°C) to +125°F (+51°C)
Arctic Kit operational temperature range	-40°F (-40°C) to 20.6°F (-5°C)

## 1-9. SUPPORT EQUIPMENT

- a. Support equipment issued with your Night Sight is listed in Appendixes B and C. Appendix D lists the expendable supplies and materials that you will need to keep your Night Sight in number one operating condition.
- b. Laser Infrared Observation Set AN/GVS-5.

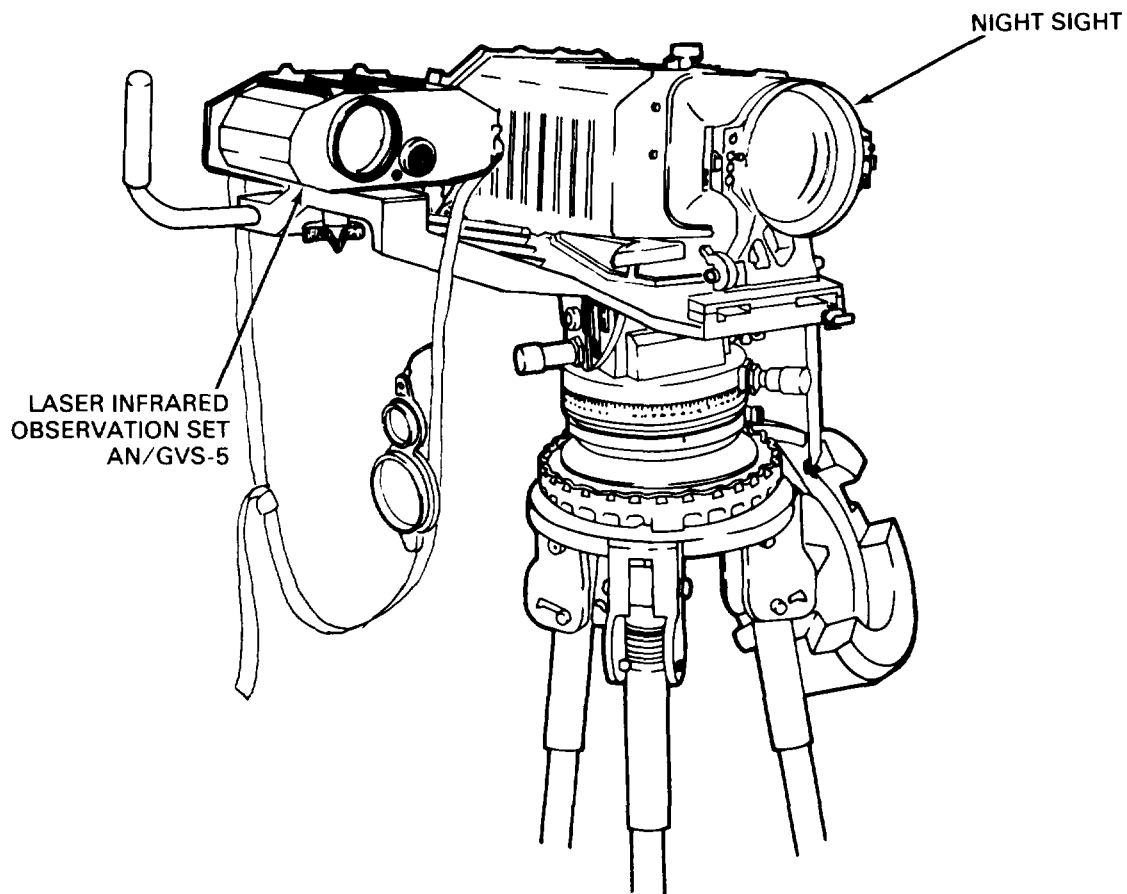

The AN/GVS-5 is used in conjunction with the Night Sight to accurately determine target distance. It is mounted beside the Night Sight on the traverse head. The AN/GVS-5 is aligned with the Night Sight using the Boresight Collimator.

Section III. FUNCTIONAL DESCRIPTION

<u>SECTION CONTENTS</u>	<u>PARA</u>	<u>PAGE</u>
SCOPE	1-10	1-16
FUNCTIONAL DESCRIPTION	1-11	1-16

**1-10. SCOPE**

This section provides a functional description of the Night Sight.

**1-11. FUNCTIONAL**

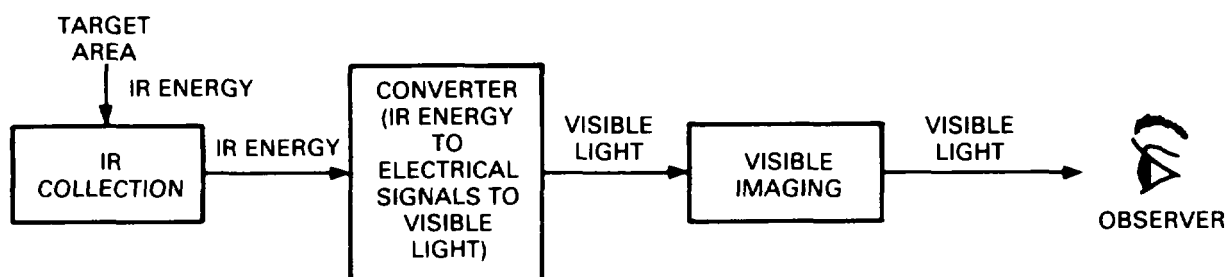

The Night Sight receives heat emissions (infrared energy) from a target area, converts the infrared (IR) energy to electrical signals (video) and then to visible light, and displays the visible light as a real-time scene for viewing by an observer.



## CHAPTER 2

### OPERATING INSTRUCTIONS

---

#### CHAPTER OVERVIEW

This chapter tells the operator how to operate and maintain the AN/UAS-11 Equipment Set.

CHAPTER CONTENTS	PAGE
Section I. DESCRIPTION AND USE OF OPERATOR'S CONTROLS AND INDICATORS	2-1
Section II. PREVENTIVE MAINTENANCE CHECKS AND SERVICES	2-10
Section III. EMPLACEMENT OF NIGHT SIGHT	2-25
Section IV. OPERATION UNDER USUAL CONDITIONS	2-44
Section V. OPERATION UNDER UNUSUAL CONDITIONS	2-58
Section VI. COMPONENT STOWAGE AND TRANSPORTATION DATA	2-65

#### **Section I. DESCRIPTION AND USE OF OPERATOR'S CONTROLS AND INDICATORS**

SECTION CONTENTS	PARA	PAGE
SCOPE	2-1	2-2
NIGHT SIGHT CONTROLS AND INDICATORS	2-2	2-2
BORESIGHT COLLIMATOR CONTROLS AND INDICATORS	2-3	2-6
TRAVERSE HEAD ASSEMBLY CONTROLS AND INDICATORS	2-4	2-7
VEHICLE POWER CONDITIONER CONTROLS	2-5	2-9

## 2-1. SCOPE

This section identifies the controls and indicators of the components of the AN/UAS-11 Equipment. Listed next to each control or indicator is a brief description of its purpose and use.

## 2-2. NIGHT SIGHT CONTROLS AND INDICATORS



- This equipment is a precision electro-optical instrument and must be handled carefully.
- Do not use MI antifogging kit on front lens of Night Sight because it will degrade the infrared image. See lens cleaning instructions (para 2-8).
- Keep protective cap on front lens at all times when not in use.  
Use canvas equipment cover to protect the Night Sight when it is not in use.

### NOTE

- If equipment fails to operate refer to troubleshooting procedure in Chapter 3.
- Night Sight may be tested or used in daylight without damage to Night Sight.

2-2. NIGHT SIGHT CONTROLS AND INDICATORS (CONT)

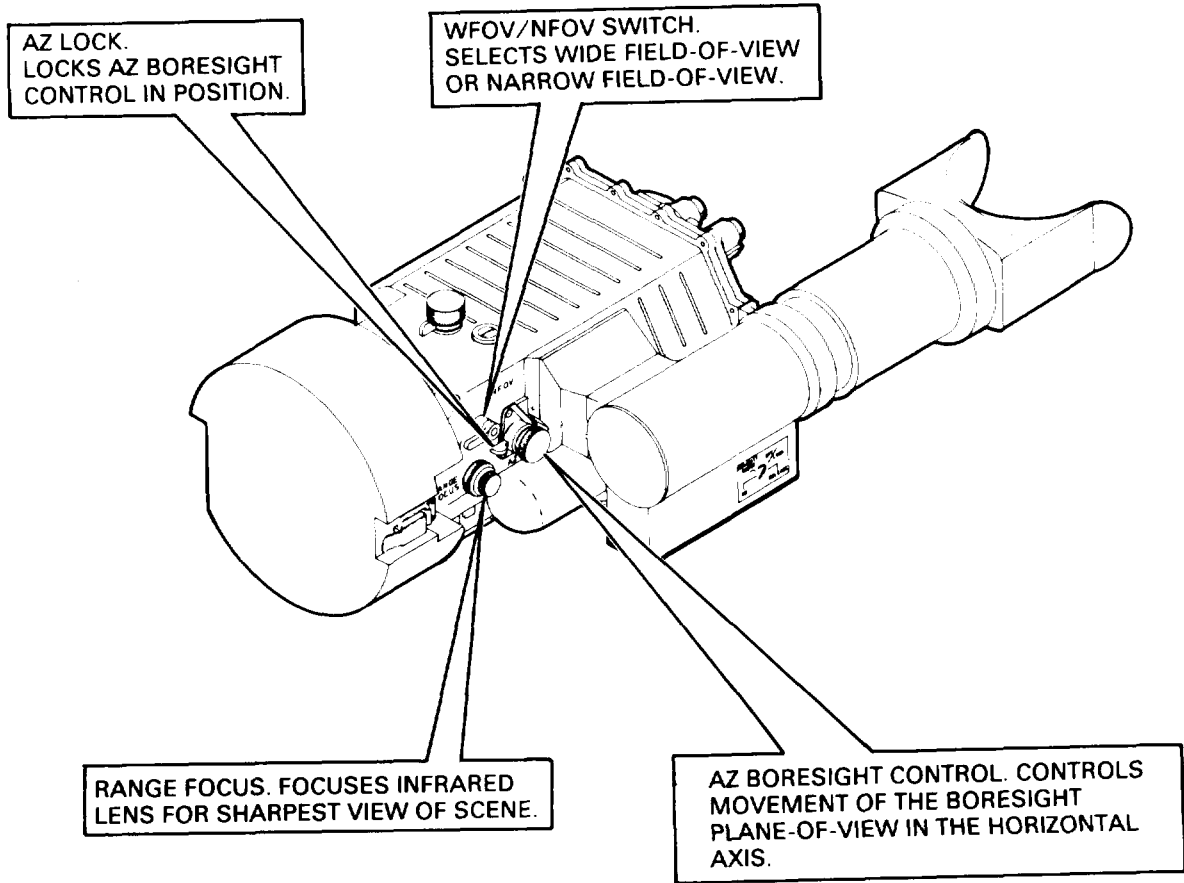

2-2. NIGHT SIGHT CONTROLS AND INDICATORS (CONT)

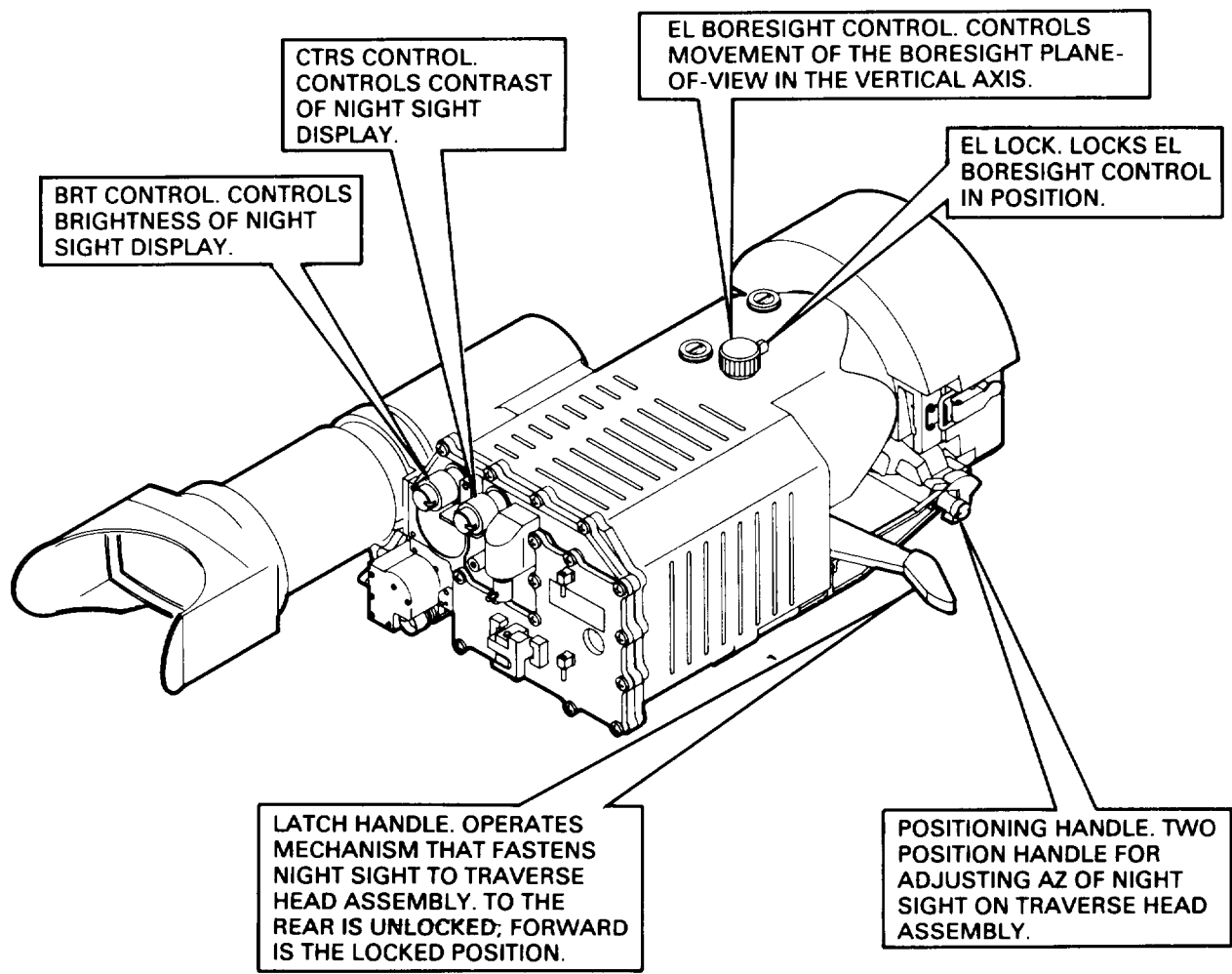

2-2. NIGHT SIGHT CONTROLS AND INDICATORS (CONT)

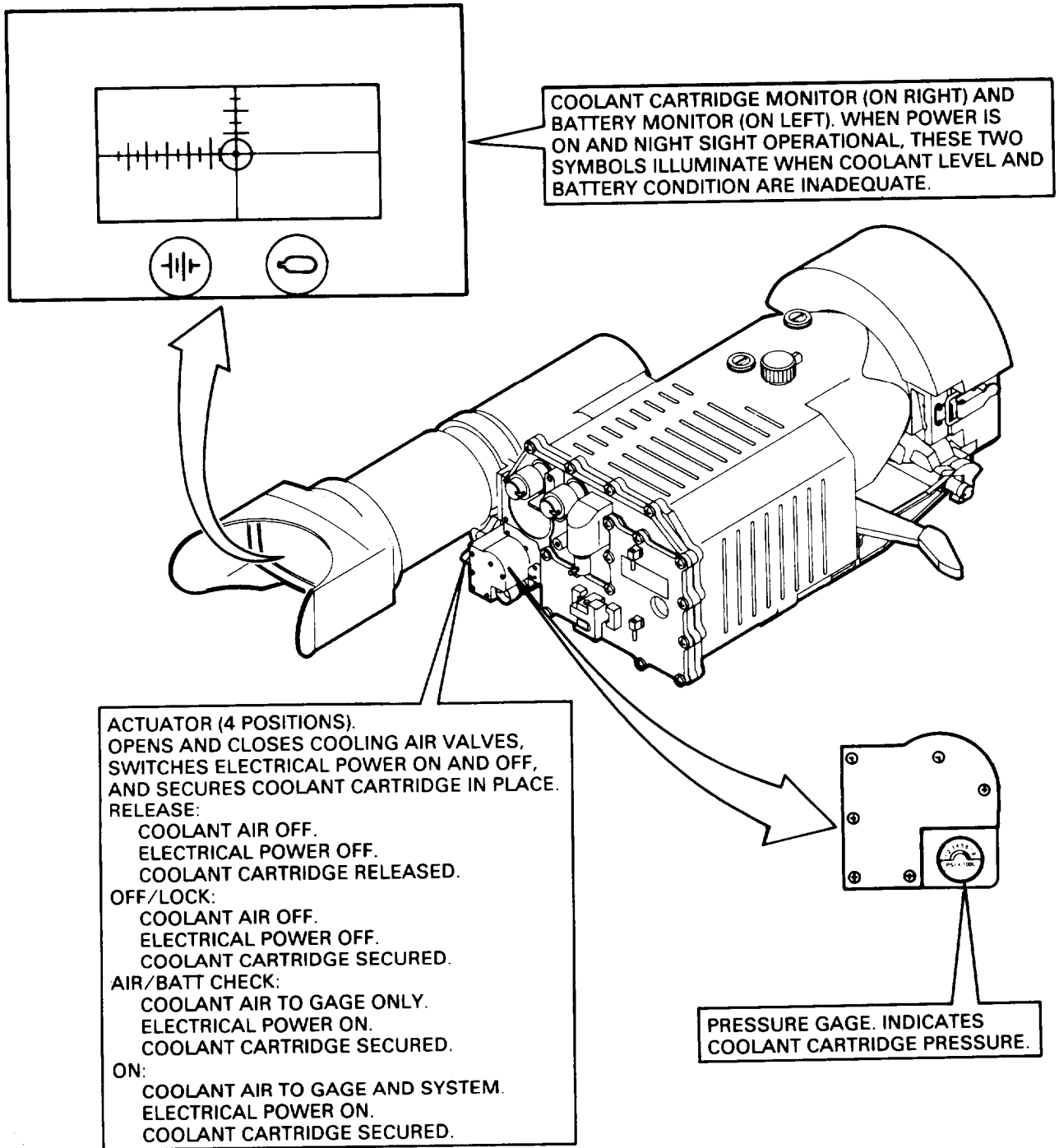

### 2-3. BORESIGHT COLLIMATOR CONTROLS AND INDICATORS

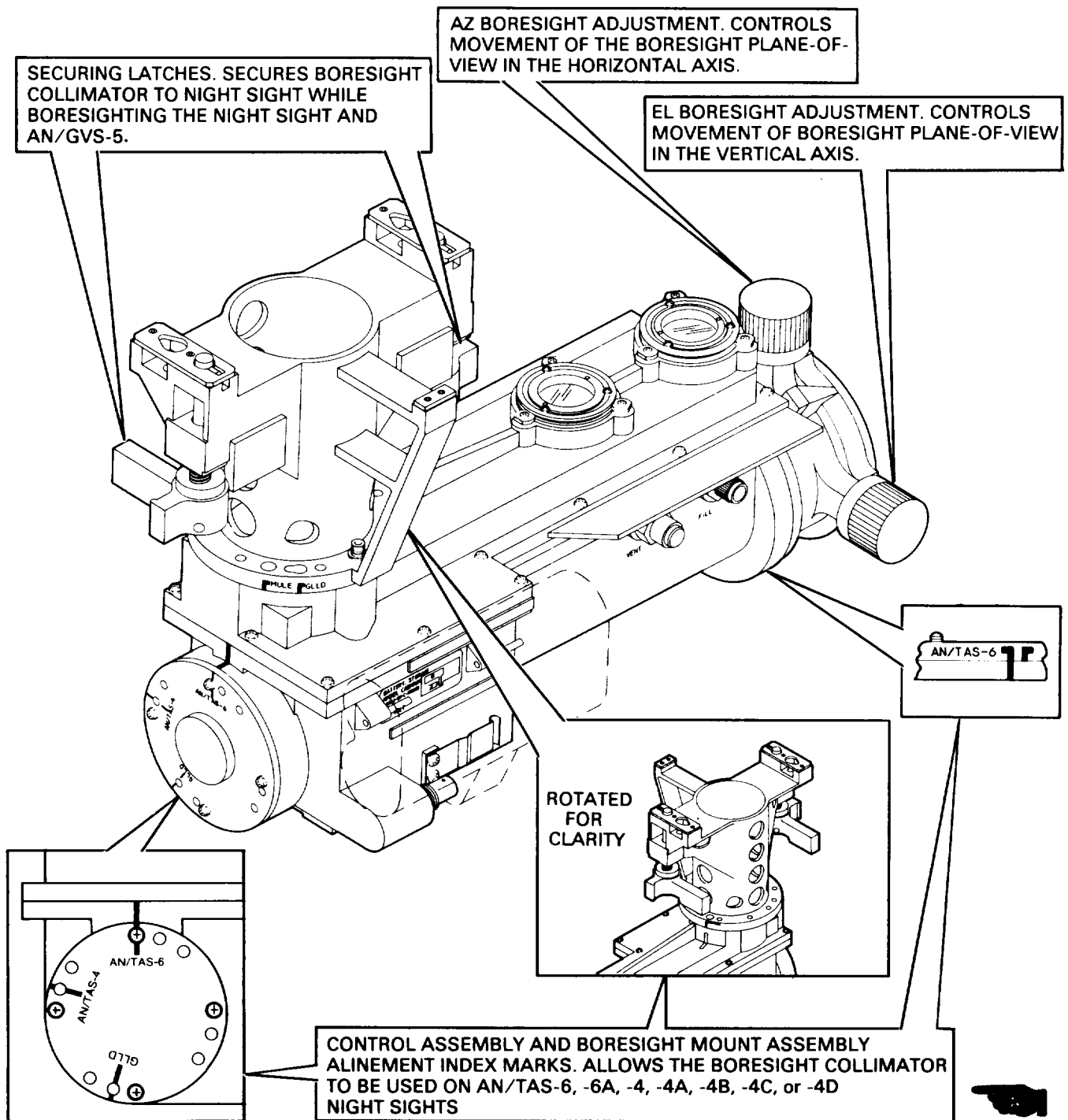

2-4. TRAVERSE HEAD ASSEMBLY CONTROLS AND INDICATORS

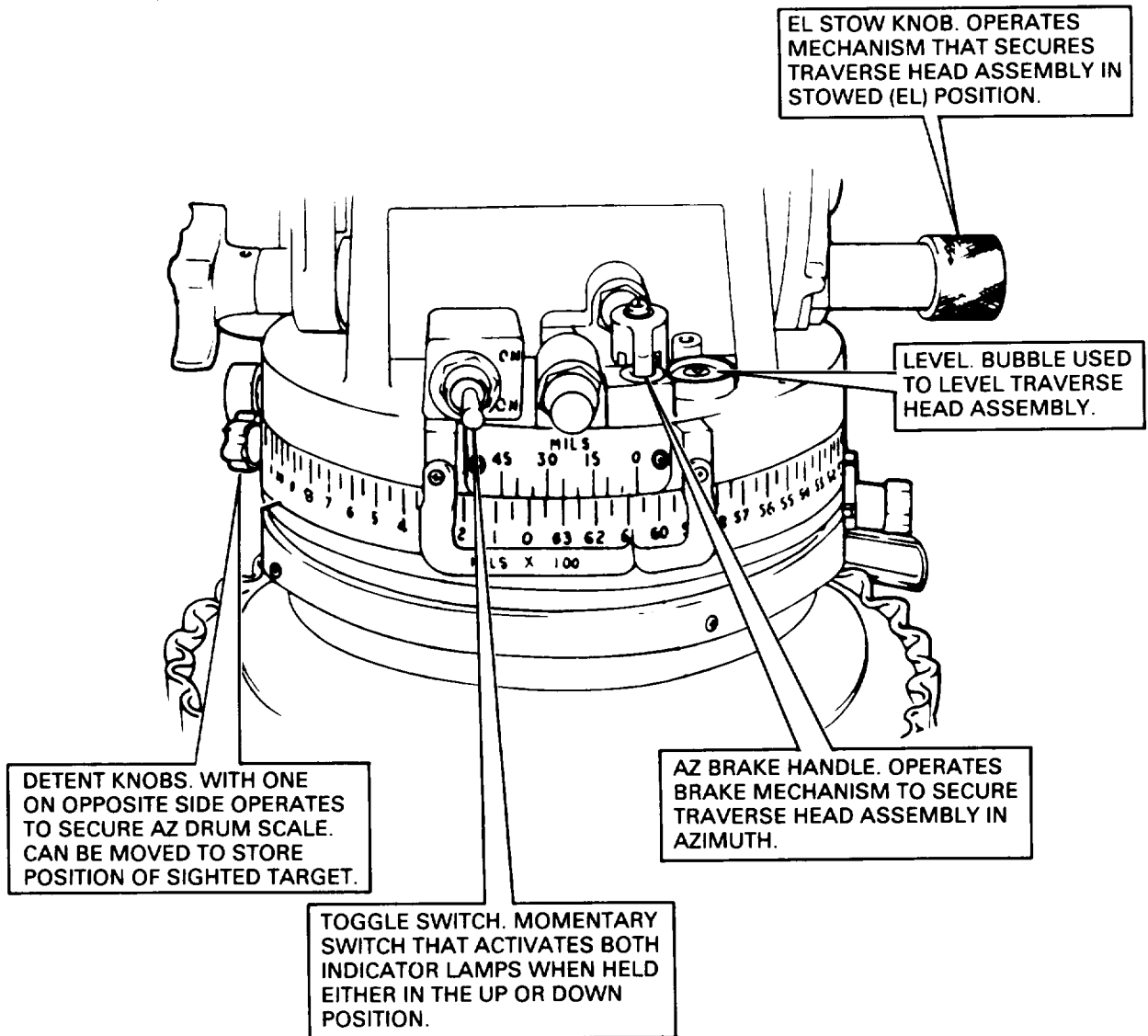

2-4. TRAVERSE HEAD ASSEMBLY CONTROLS AND INDICATORS (CONT)

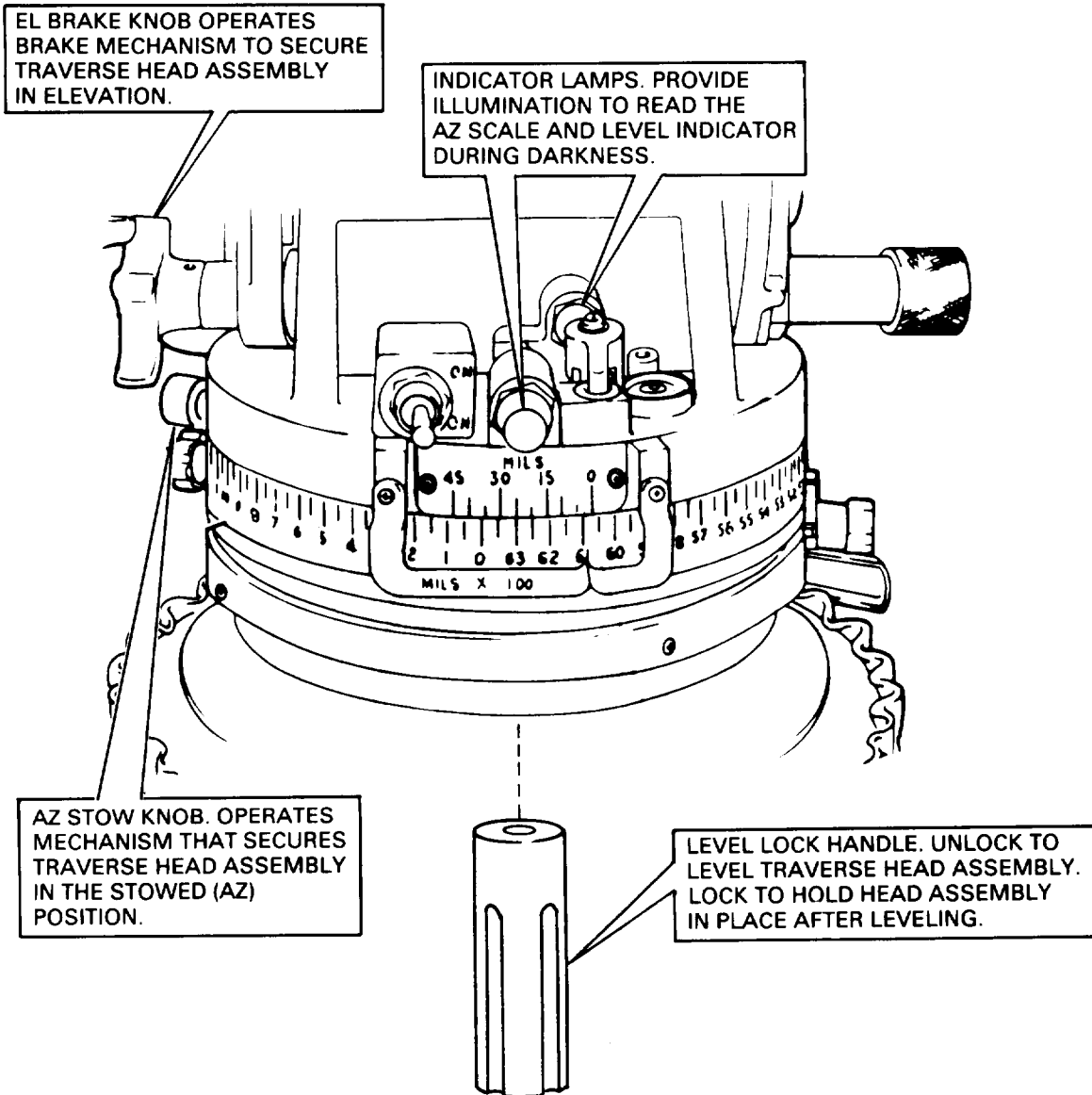



2-5. VEHICLE POWER CONDITIONER CONTROLS

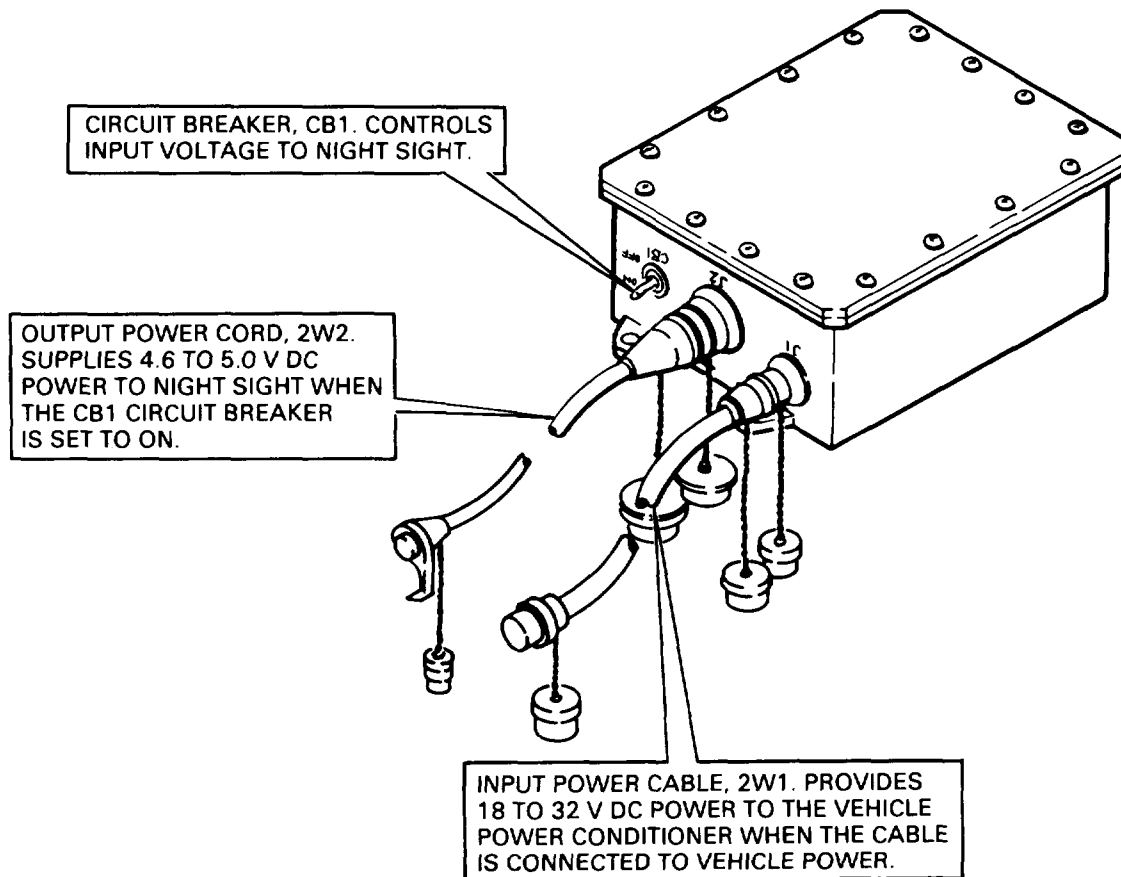

## Section II. PREVENTIVE MAINTENANCE CHECKS AND SERVICES

<u>SECTION CONTENTS</u>	PARA	PAGE
SCOPE	2-6	2-10
SERVICE TO AN/UAS-11 EQUIPMENT SET	2-7	2-11
PREVENTIVE MAINTENANCE CHECKS AND SERVICES (PMCS)	2-8	2-17

### 2-6. SCOPE

This section presents the Preventive Maintenance Checks and Services that must be performed on the AN/UAS-11 Equipment Set. It also identifies the services required prior to use.

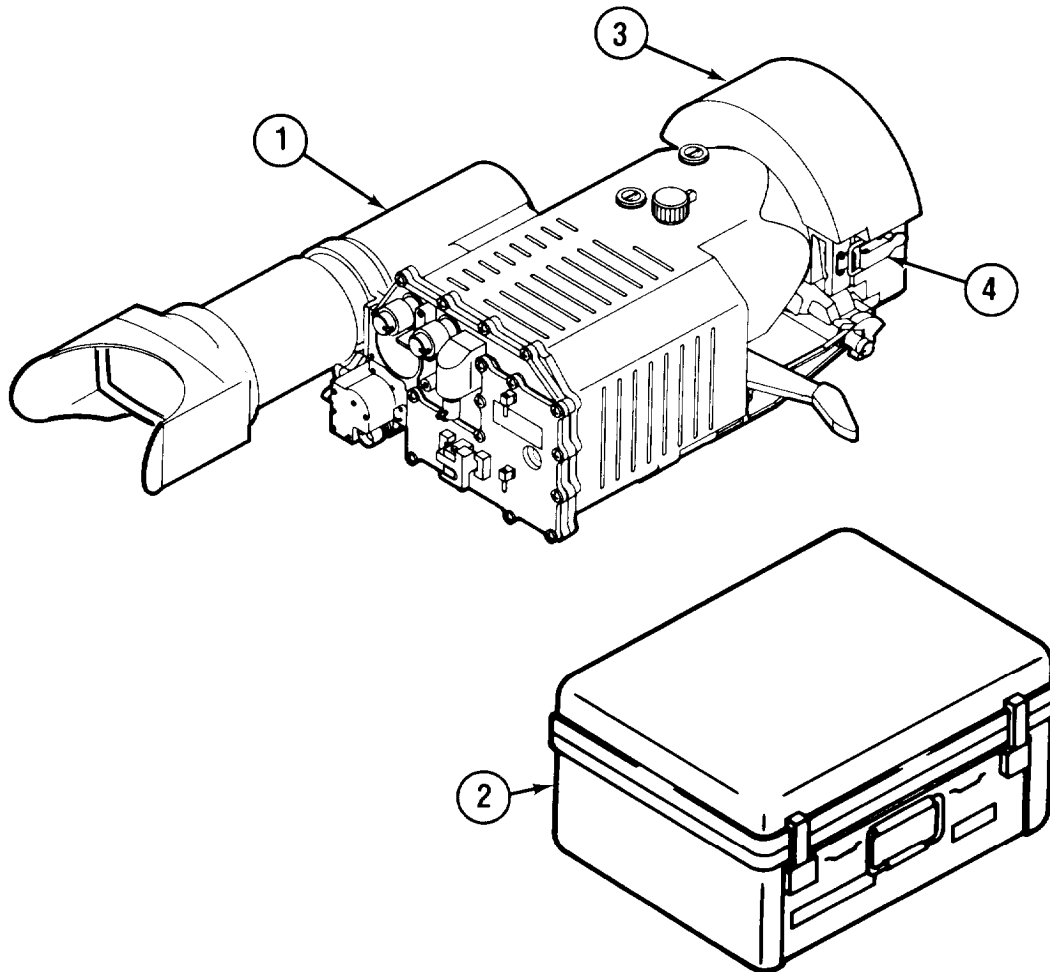
**2-7. SERVICE TO AN/UAS-11 EQUIPMENT SET**  
(Sheet 1 of 6)

- A. Remove Night Sight (1) from Night Sight case (2).
- B. If Night Sight (1) is to be used without the vehicle power conditioner, install a freshly charged battery (para 2-16).
- C. Remove afocal guard cushion (3) by releasing the two latches (4). Verify lens is not loose, broken, or dirty.
- D. Install afocal guard cushion (3) and secure latches (4).

GO TO NEXT PAGE

2-7. SERVICE TO AN/UAS-11 EQUIPMENT SET (CONT)  
(Sheet 2 of 6)

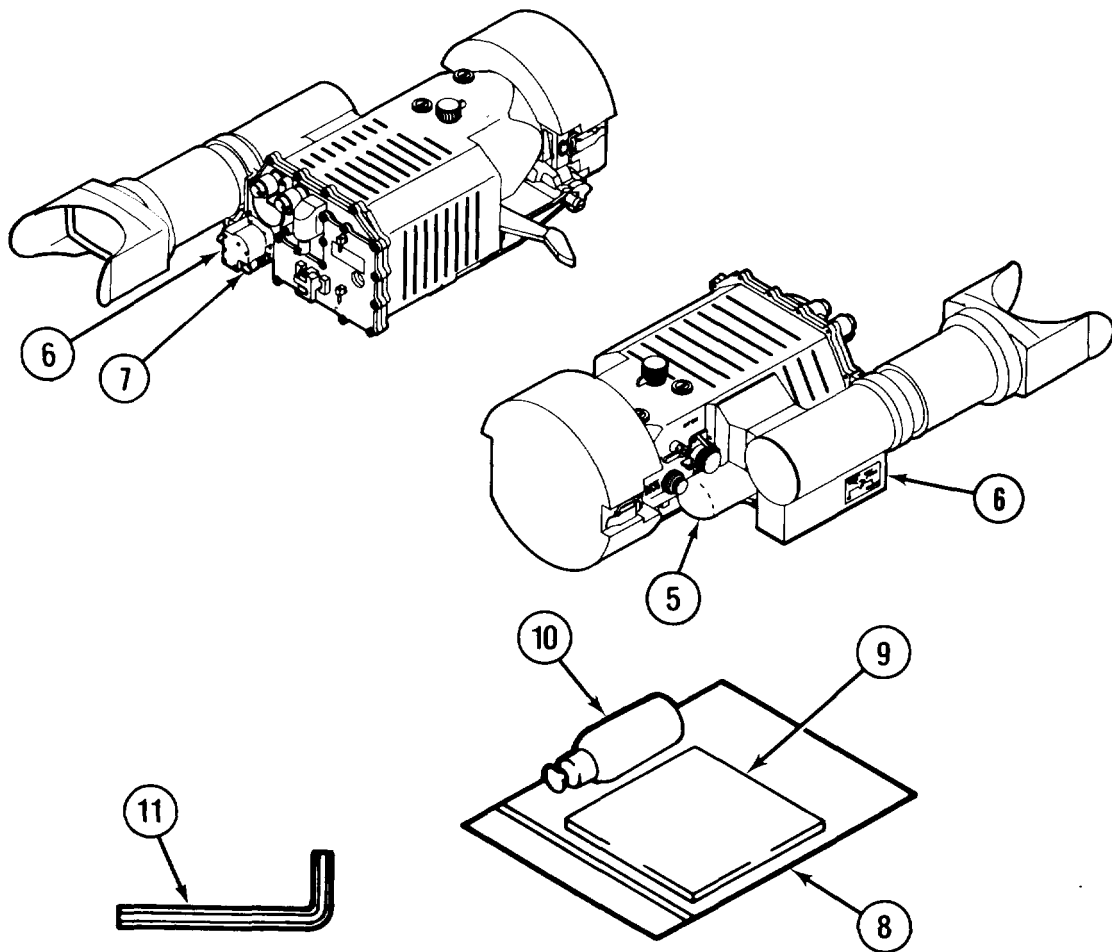

- E. Check that coolant cartridge (5) is installed (para 3-6).
- F. Turn actuator (6) to ON position (fully counterclockwise).
- G. Check to see that coolant pressure gage (7) indicates between 1,000 and 6,000 PSI. If not, replace coolant cartridge (para 3-6).
- H. Be sure lens cleaning kit bag (8) is complete with cotton pads (9), bottle (10) and socket-head screw key (11). The bottle (10) is shipped empty and must be filled with cleaning solution (Item 4, Appendix D).

GO TO NEXT PAGE

2-7. SERVICE TO AN/UAS-11 EQUIPMENT SET (CONT)  
(Sheet 3 of 6)

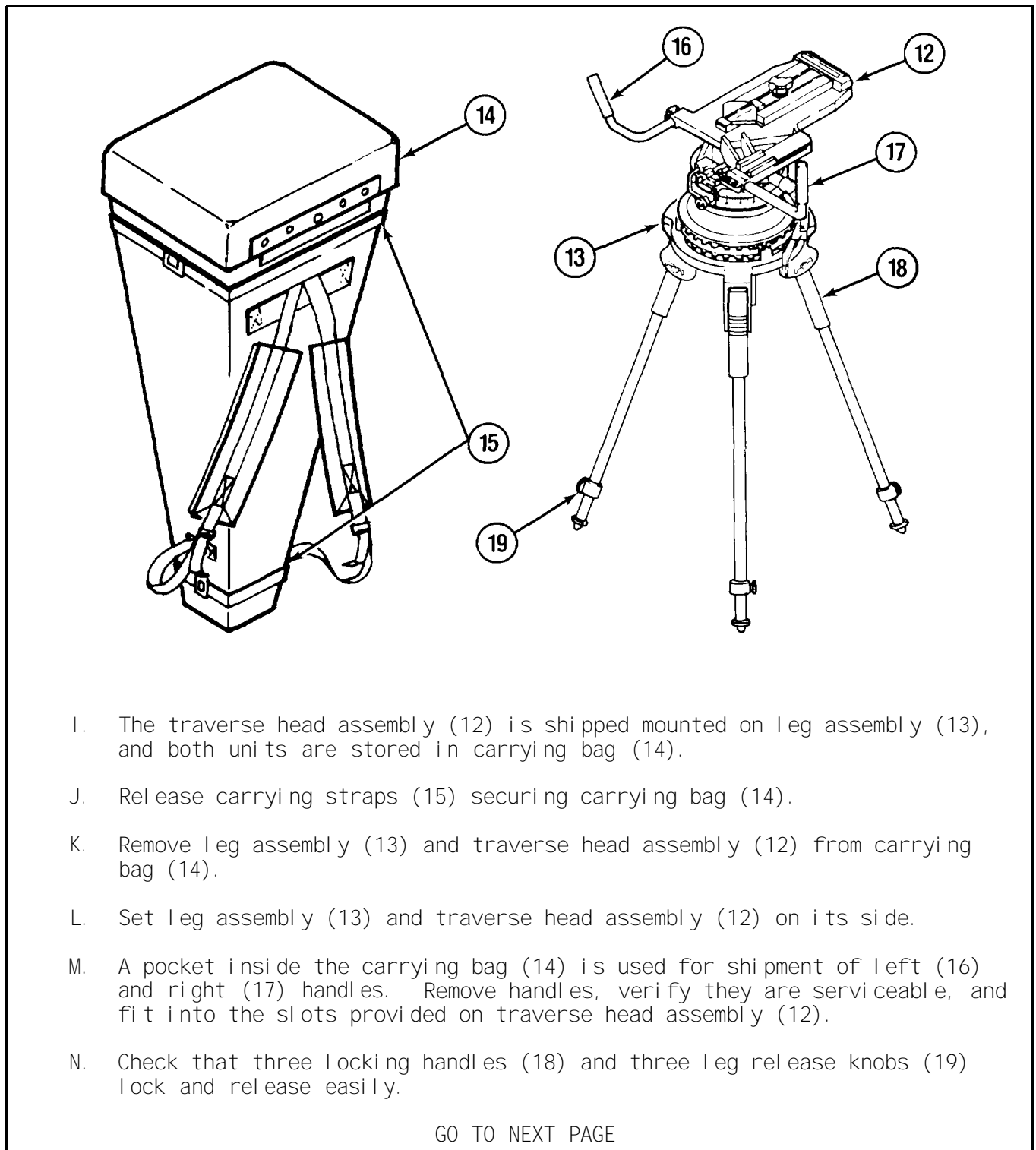

2-7. SERVICE TO AN/UAS-11 EQUIPMENT SET (CONT)  
(Sheet 4 of 6)

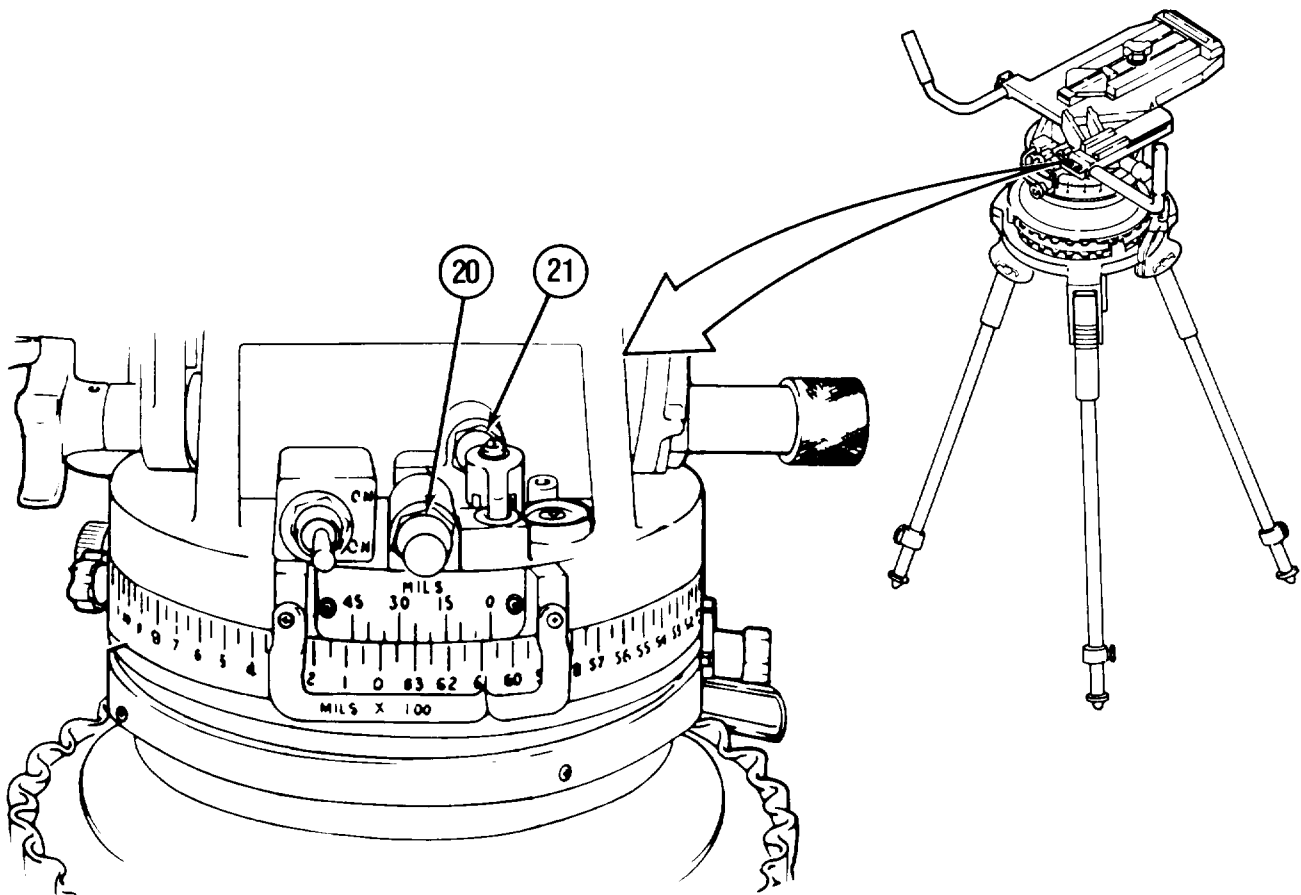

- o. Insure azimuth scale lamp (20) and level indicator lamp (21) illuminate; if not, replace battery (para 2-15).
- P. Check vehicle power conditioner (22) for overall condition, insuring that there are no broken parts.

GO TO NEXT PAGE

2-7. SERVICE TO AN/UAS-11 EQUIPMENT SET (CONT)  
(Sheet 5 of 6)

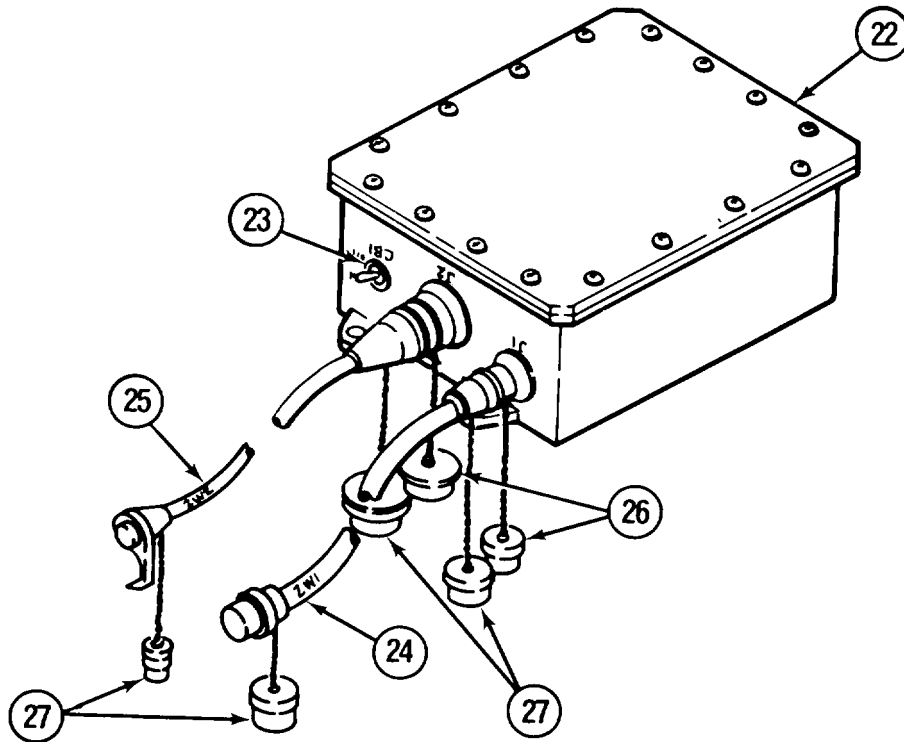

- Q. Check that circuit breaker CB1 (23) works smoothly and is set to OFF position.
- R. Check that input cable 2W1 (24) and output cable 2W2 (25) are neither cut nor frayed. Check for dirt, corrosion, or bent and broken pins.
- s. Check that all protective caps (26) are connected to the vehicle power conditioner (22). Check that all protective caps (27) are connected to the power cables (24) and (25).

GO TO NEXT PAGE

2-7. SERVICE TO AN/UAS-11 EQUIPMENT SET (CONT)  
(Sheet 6 of 6)

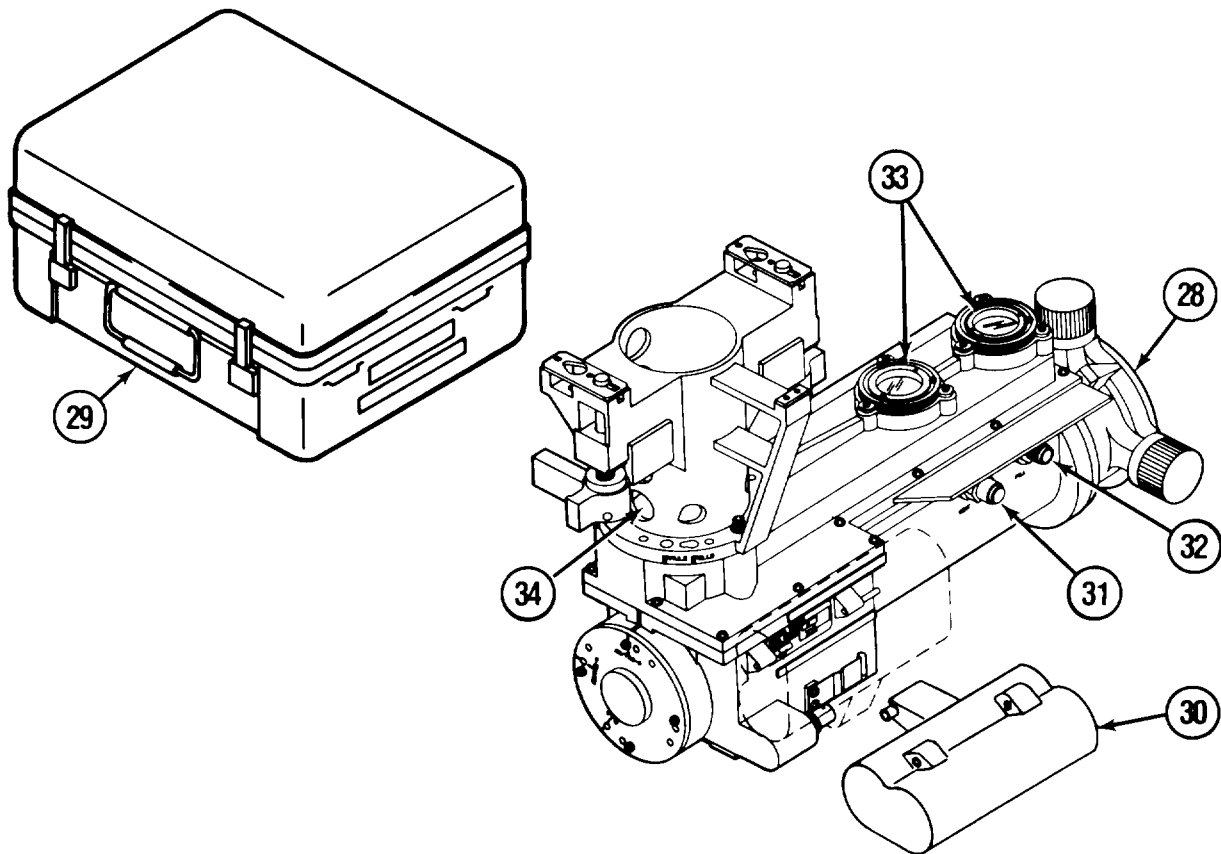

- T. Remove Boresight Collimator (28) from its case (29). Check case (29) for broken parts.
- U. Check that a battery (30) is available and charged.

NOTE

The Boresight Collimator uses the same type batteries supplied with Night Sight.

- v. Check safety relief valve (31) and filler valve (32) for cleanliness, tightness of nuts, and general condition.
- w. Check visible light windows (33) and IR window (34) for cleanliness, moisture, cracks, or breaks.
- x. Insure Boresight Collimator (28) has been aligned within 180 days (refer to TM 9-5855-286-14).

END OF TASK



**2-8. PREVENTIVE MAINTENANCE CHECKS AND SERVICES (PMCS)  
(Sheet 1 of 8)**

B - Before      D - During      A - After					
(1) Item No.	(2) Interval			(3) Item to be inspected Procedure	(4) Equipment is not ready/available if:
	B	D	A		
1.	•			Container  Check exterior of container for cracks in case and for loose or missing hardware. Check for cleanliness (para 2-8).	Cracks or other obvious damage exist in container.

1 Column 1, Item No. Column 1 numbers the checks and services to be performed in chronological order. This column will also be used as a source of item numbers for the "TM Number" column on DA Form 2404, Equipment Inspection and Maintenance worksheet, in recording results of PMCS.

2 Column 2, Interval. Column 2 specifies the intervals at which the PMCS will be performed. A dot (•) in any "Interval" column indicates when you are to perform that PMCS. The letters indicate the interval as follows:

- B - Before operation
- D - During operation
- A - After operation

3 Column 3, Item to be inspected Procedure. Column 3 identifies the part of the equipment to be checked and the procedures for performing the check.

4 Column 4, Equipment is not ready/available if: Column 4 contains the criteria which will cause the equipment to be unable to perform its primary function.

**2-8. PREVENTIVE MAINTENANCE CHECKS AND SERVICES (PMCS) (CONT)**  
**(Sheet 2 of 8)**

Before you begin the preventive maintenance checks, keep in mind the following general information.

- A. Before operating any equipment, do all the before (B) PMCS. Be sure to keep in mind all CAUTIONS and WARNINGS.
- B. While operating any equipment, do all the during (D) PMCS. Be sure to keep in mind all CAUTIONS and WARNINGS.
- C. After operating any equipment, do all the after (A) PMCS.

TABLE 2-1. PREVENTIVE MAINTENANCE CHECKS AND SERVICES

B - Before    D - During    A - After					
Item No.	Interval			Item to be inspected Procedure	Equipment is not ready/available if:
	B	D	A		
1	●		●	See that the equipment is complete. (See Appendix B)	Any equipment is missing.
2				EYEPIECE AND FRONT LENS	
	●		●	1) Remove lens cover. Examine lens for chips, cracks, scratches, or breaks.	Any cracks or breaks exist.
	●		●	2) Inspect for dirt, dust, oil, and fingerprints.	Night Sight Vision obscured.
				<div style="border: 2px dashed black; padding: 5px; width: fit-content; margin: 0 auto;"><b>CAUTION</b></div> <p>The Night Sight lens is easily damaged. Avoid scratches by not rubbing cleaning solution (Item 4, Appendix D) on surface. Do not allow container to contact lens during cleaning or flushing procedures. Use only approved materials and procedures for cleaning lens.</p>	

**2.8 PREVENTIVE MAINTENANCE CHECKS AND SERVICES (PMCS) (CONT)**  
**(Sheet 3 of 8)**

TABLE 2-1. PREVENTIVE MAINTENANCE CHECKS AND SERVICES (CONT)

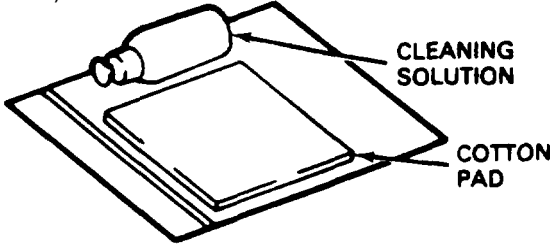
				B - Before	D - During	A - After			
Item No.	Interval			Item to be inspected Procedure	Equipment is not ready/available if:				
	B	D	A						
3	●			<p style="text-align: center;"><b>CLEAN LENS (if necessary)</b></p> <p style="text-align: center;"><b>NOTE</b></p> <p>To clean the eyepiece lens, the eyeshield may be removed from Night Sight (para 3-7).</p> <p>Flush off surface of lens with potable water (clean water suitable for drinking) to remove dust and grit.</p> <p>Thoroughly moisten cotton pad (Item 2, Appendix D) from Night Sight lens cleaning kit with denatured alcohol (Item 4, Appendix D).</p> <div style="text-align: center;">  <p><b>LENS CLEANING KIT MS015522</b></p> </div> <p>(a) Apply lens denatured alcohol (Item 4, Appendix D) to lens by dabbing lightly (do not rub) until lens surface is evenly covered.</p> <p>(b) Wait one to three minutes, depending on condition, for solution to loosen heavy contamination. (Do not allow solution to dry. )</p> <p>(c) Flush off solution with potable water.</p>		<p>Cleaning does not clear lens.</p>			

**2-8. PREVENTIVE MAINTENANCE CHECKS AND SERVICES (PMCS) (CONT)**  
**(Sheet 4 of 8)**

TABLE 2-1. PREVENTIVE MAINTENANCE CHECKS AND SERVICES (CONT)

B - Before      D - During      A - After					
Item No.	Interval			Item to be inspected Procedure	Equipment is not ready/available if:
	B	D	A		
4	✓			<p>Repeat (a), (b), and (c) above until heavy contamination is removed. Clean lens in small sections by applying denatured alcohol (Item 4, Appendix D) and gently wiping with clean cotton pad (Item 2, Appendix D).</p> <p style="text-align: center;"><b>CAUTION</b></p> <p>Wiping motion should be accomplished in one direction only. Discard cotton pad after using. Do not use again.</p> <p>Rinse lens with potable water.</p> <p>Dry lens by wiping lightly in a single direction with clean cotton pads.</p> <p>During freezing weather, ice may be melted from the lens by using heating pad pack (Item 3, Appendix D) from Arctic Kit.</p> <p>Inspect for internal condensation inside eyepiece.</p>	Internal condensation present.

2-8. PREVENTIVE MAINTENANCE CHECKS AND SERVICES (PMCS) (CONV  
(Sheet 5 of 8)

TABLE 2-1. PREVENTIVE MAINTENANCE CHECKS AND SERVICES (CONT)

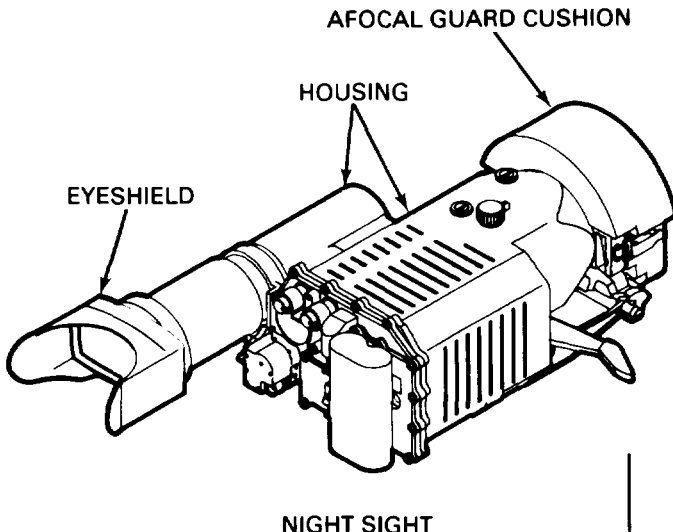
				B- Before      D - During      A - After				
Item No.	Interval			Item to be inspected Procedure	Equipment is not ready/available if:			
	B	D	A					
5			•	<p><b>EXTERIOR SURFACES</b></p> <p>If necessary, clean exterior surfaces using a cloth dampened with clean water, then wipe clean with clean, dry, lint-free cloth.</p> <p>• Inspect housing for scratches, cracks, or other damage. Report damage to next higher level maintenance.</p>	Damage impairs operation.			
	•		•					
6	•		•	<p><b>AFOCAL GUARD CUSHION</b></p> <p>Inspect for holes, rips, broken or missing latches, or other damage.</p>	Damage impairs operation.			

2-8. PREVENTIVE MAINTENANCE CHECKS AND SERVICES (PMCS) (CONT)  
(Sheet 6 of 8)

TABLE 2-1. PREVENTIVE MAINTENANCE CHECKS AND SERVICES (CONT)

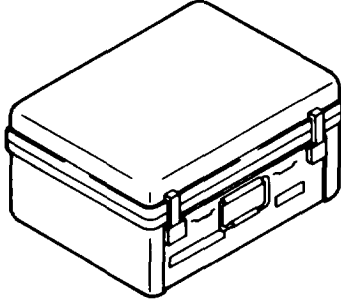
B- Before      D - During      A - After					
Item No.	Interval			Item to be inspected Procedure	Equipment is not ready/available if:
	B	D	A		
7				 <p style="text-align: center;">FIELD HANDLING CASE</p> <p style="text-align: center;">FIELD HANDLING CASE</p> <p>Insure that inside of case is clean and dry. If necessary, turn case over and shake out grit and dirt, then wipe interior and exterior with a cloth dampened with clean water. Dry with clean, dry, lint-free cloth.</p>	Field handling case broken or bent badly enough that it will not close and latch.

2-8. PREVENTIVE MAINTENANCE CHECKS AND SERVICES (PMCS) (CONT)  
(Sheet 7 of 8)

TABLE 2-1. PREVENTIVE MAINTENANCE CHECKS AND SERVICES (CONT)

				B - Before	D - During	A - After		
Item No.	Interval			Item to be inspected Procedure			Equipment is not ready/available if:	
	B	D	A					
8	•			Perform Troubleshooting Procedures (para 3-2)		Any performance impairs operation.		
9		•		<p style="text-align: center;">OPERATION</p> <p>During operation, be alert for any unusual performance conditions. Report any damage, unusual performance, defective controls, or other failures, to higher level of maintenance.</p>		Any damage or unusual performance impairs operation.		

  

The diagram shows a perspective view of a cylindrical device with a lens on the left. Four controls are labeled with leader lines: 'EL BORESIGHT CONTROL' (a knob on the top left), 'FIELD-OF-VIEW SELECTION LEVER' (a lever on the top), 'RANGE FOCUS CONTROL' (a knob on the front), and 'AZ BORESIGHT CONTROL' (a knob on the bottom right).

2-8. PREVENTIVE MAINTENANCE CHECKS AND SERVICES (PMCS) (CONT)  
 (Sheet 8 of 8)

TABLE 2-1. PREVENTIVE MAINTENANCE CHECKS AND SERVICES (CONT)  
 B - Before D - During A - After

Item No.	Interval			Item to be inspected Procedure	Equipment is not ready/available if:
	B	D	A		
10	•			BORESIGHT COLLIMATOR	Boresight Collimator is not in AN/TAS-6 position.  Boresight Collimator has not been aligned within 180 days.
11	•				

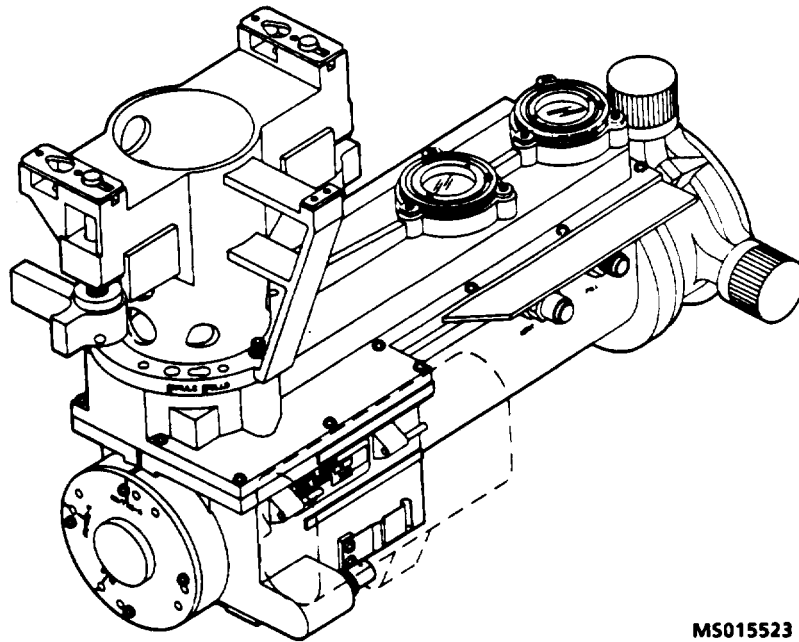

MS015523



### Section III. EMPLACEMENT OF NIGHT SIGHT

SECTION CONTENTS	PARA	PAGE
SCOPE	2-9	2-25
SETTING UP TRIPOD ASSEMBLY	2-10	2-26
SETTING UP APC MOUNT ASSEMBLY	2-11	2-27
SETTING UP NIGHT SIGHT ON TRAVERSE HEAD	2-12	2-28
SETTING UP AN/GVS-5 TO NIGHT SIGHT	2-13	2-30
CONNECTING VEHICLE POWER CONDITIONER	2-14	2-31
INSTALLING BATTERY IN TRAVERSE HEAD ASSEMBLY	2-15	2-33
CONNECTING RECHARGEABLE BATTERY TO NIGHT SIGHT	2-16	2-34
LEVELING PROCEDURE	2-17	2-35
COLLIMATING AN/GVS-5 TO NIGHT SIGHT	2-18	2-36

#### **2-9. SCOPE**

This section provides setup procedures for the two types of mounts used to support the traversing head and Night Sight. The Night Sight can be mounted on a Tripod assembly or APC Mount Assembly.

2-10. SETTING UP TRIPOD ASSEMBLY

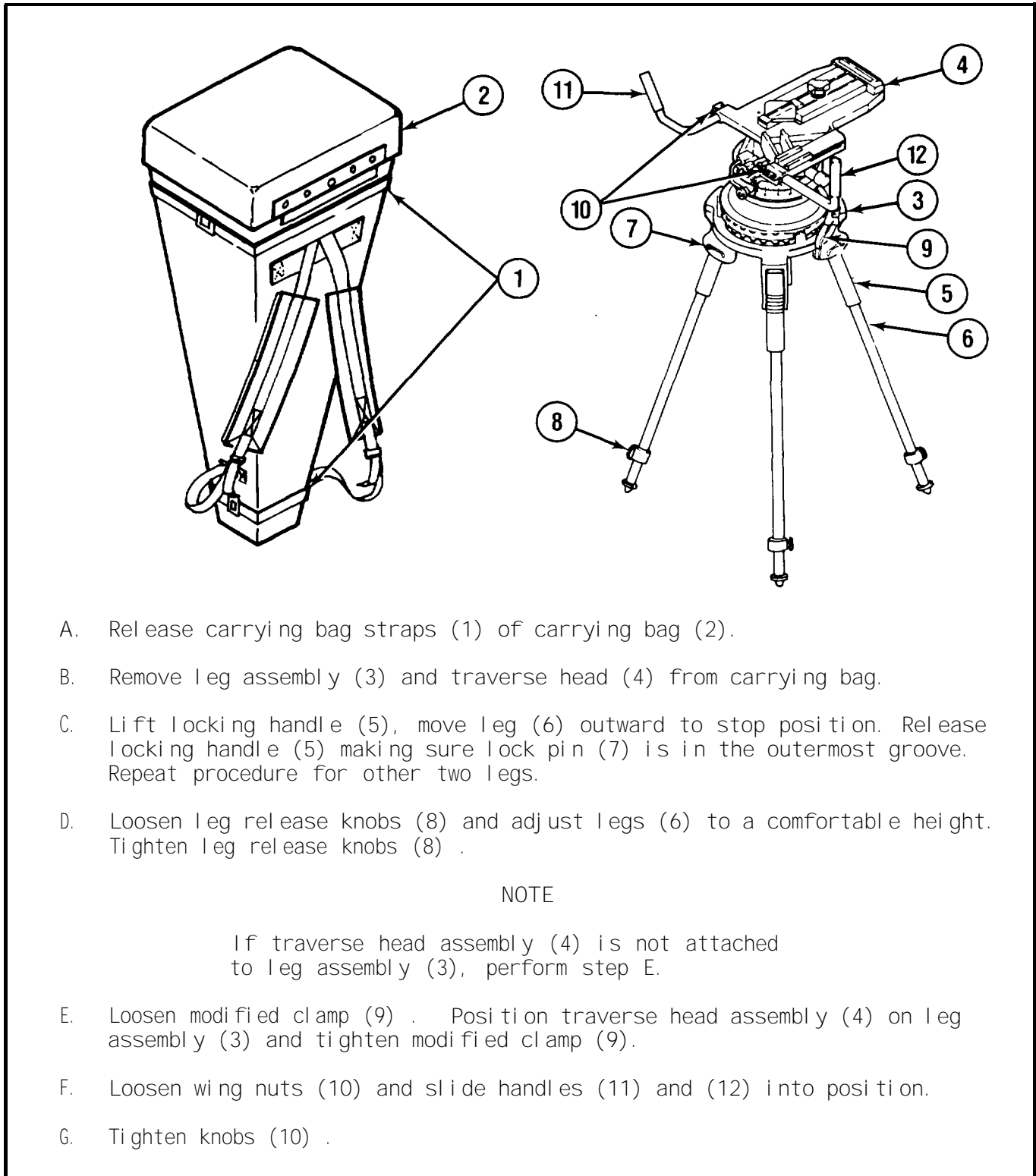

- A. Release carrying bag straps (1) of carrying bag (2).
- B. Remove leg assembly (3) and traverse head (4) from carrying bag.
- C. Lift locking handle (5), move leg (6) outward to stop position. Release locking handle (5) making sure lock pin (7) is in the outermost groove. Repeat procedure for other two legs.
- D. Loosen leg release knobs (8) and adjust legs (6) to a comfortable height. Tighten leg release knobs (8).

NOTE

If traverse head assembly (4) is not attached to leg assembly (3), perform step E.

- E. Loosen modified clamp (9). Position traverse head assembly (4) on leg assembly (3) and tighten modified clamp (9).
- F. Loosen wing nuts (10) and slide handles (11) and (12) into position.
- G. Tighten knobs (10).

END OF TASK

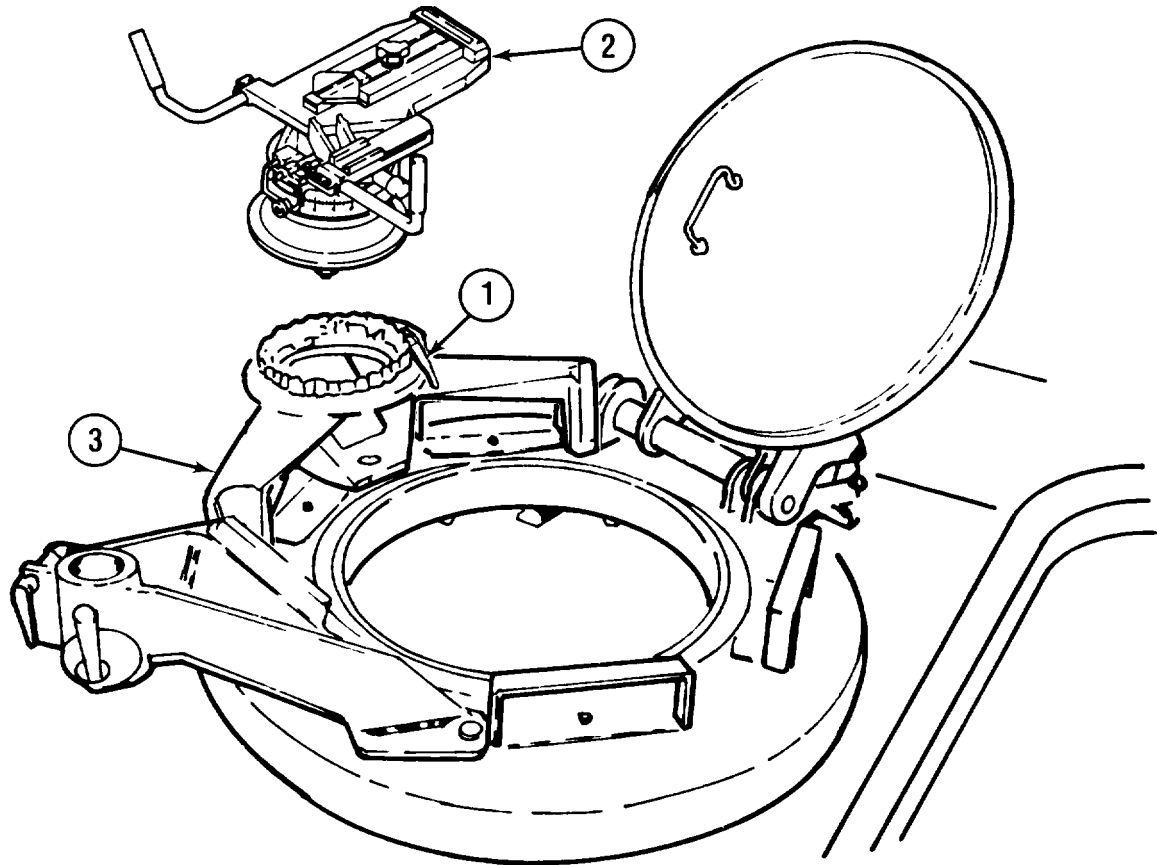
**2-11. SETTING UP APC MOUNT ASSEMBLY**

- A. Loosen modified clamp (1). Position traverse head assembly (2) on APC Mount Assembly (3).
- B. Tighten modified clamp (1).

2-12. SETTING UP NIGHT SIGHT ON TRAVERSE HEAD  
(Sheet 1 of 2)

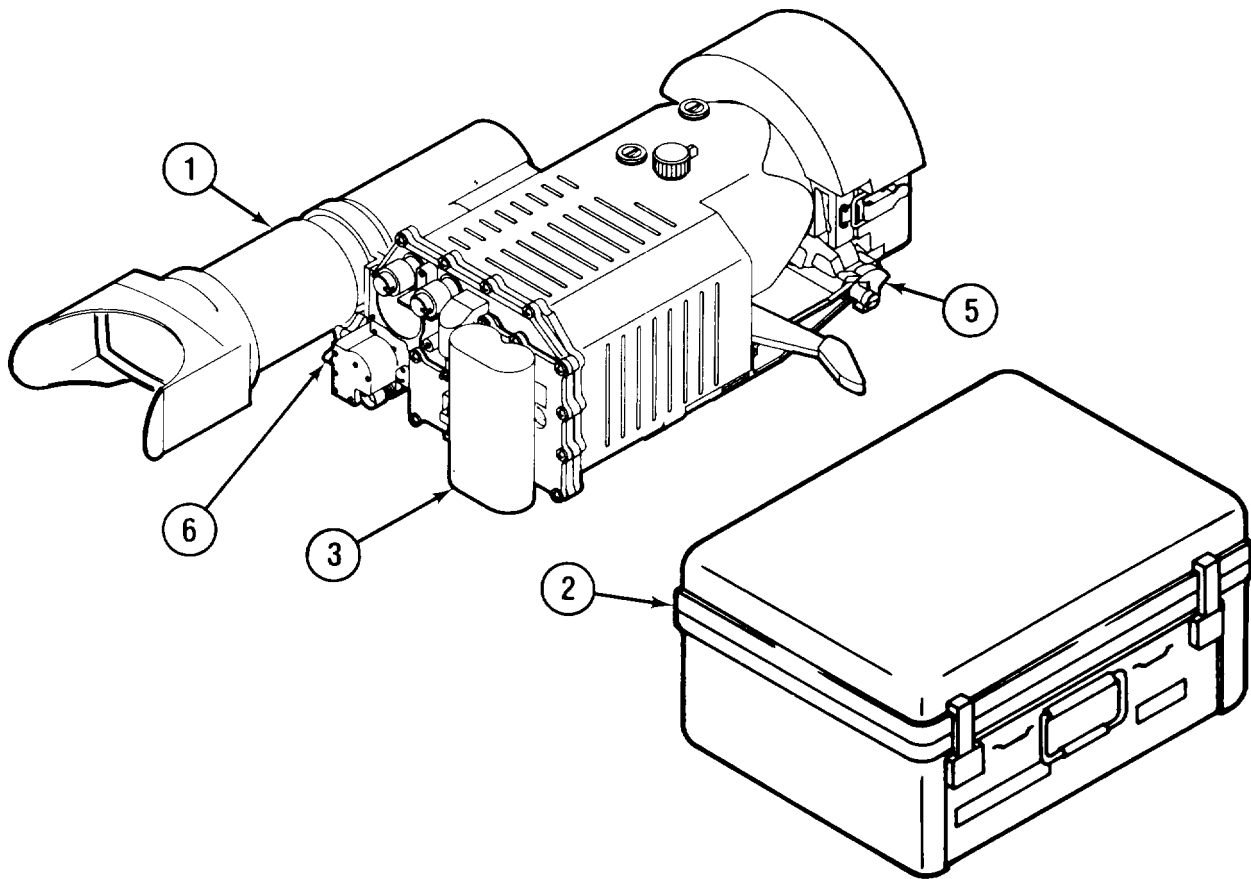

- A. Remove Night Sight (1) from field handling case (2) and check for completeness.
- B. Verify that battery (3) and coolant cartridge (4) are in place.
- C. Place positioning handle (5) in position No. 1 (forward position).

**CAUTION**

Night Sight should have coolant cartridge installed at all times other than when exchanging cartridges.

- D. Be sure that Night Sight actuator (6) is set to OFF/LOCK position.

GO TO NEXT PAGE

## 2-12. SETTING UP NIGHT SIGHT ON TRAVERSE HEAD (CONT) (Sheet 2 of 2)

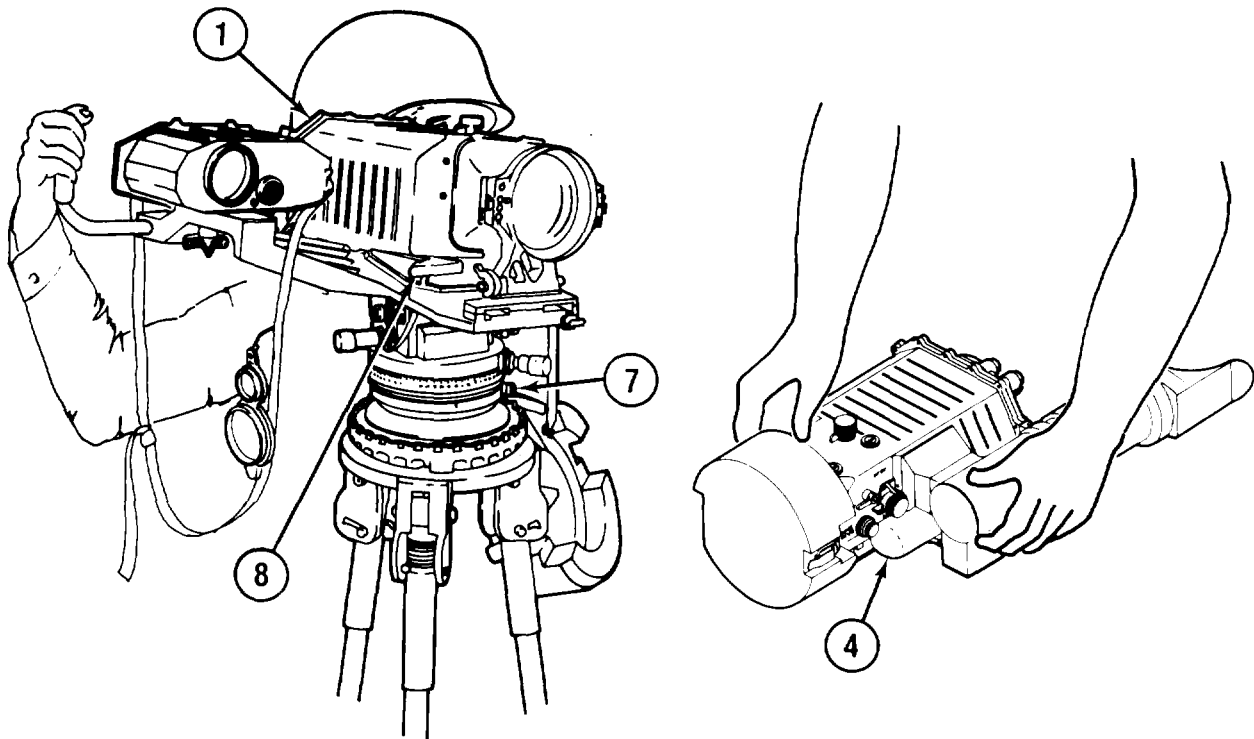

### CAUTION

- Night Sight (1) is not secured to traverse head assembly (7) until latch handle (8) is in locked position. Support Night Sight (1) with left hand while locking latch handle (8) with right hand.
  - Do not leave Night Sight installed on APC Mount Assembly while vehicle is moving. Damage to the Night Sight will result.
- E. From the rear of the traverse head assembly (7) move the Night Sight latch handle (8) to rear (unlock) position.
  - F. Align and attach Night Sight (1) to traverse head assembly (7).
  - G. Using right hand, move the latch handle (8) forward to the locked position while supporting Night Sight with left hand.

END OF TASK

2-13. SETTING UP AN/GVS-5 TO NIGHT SIGHT

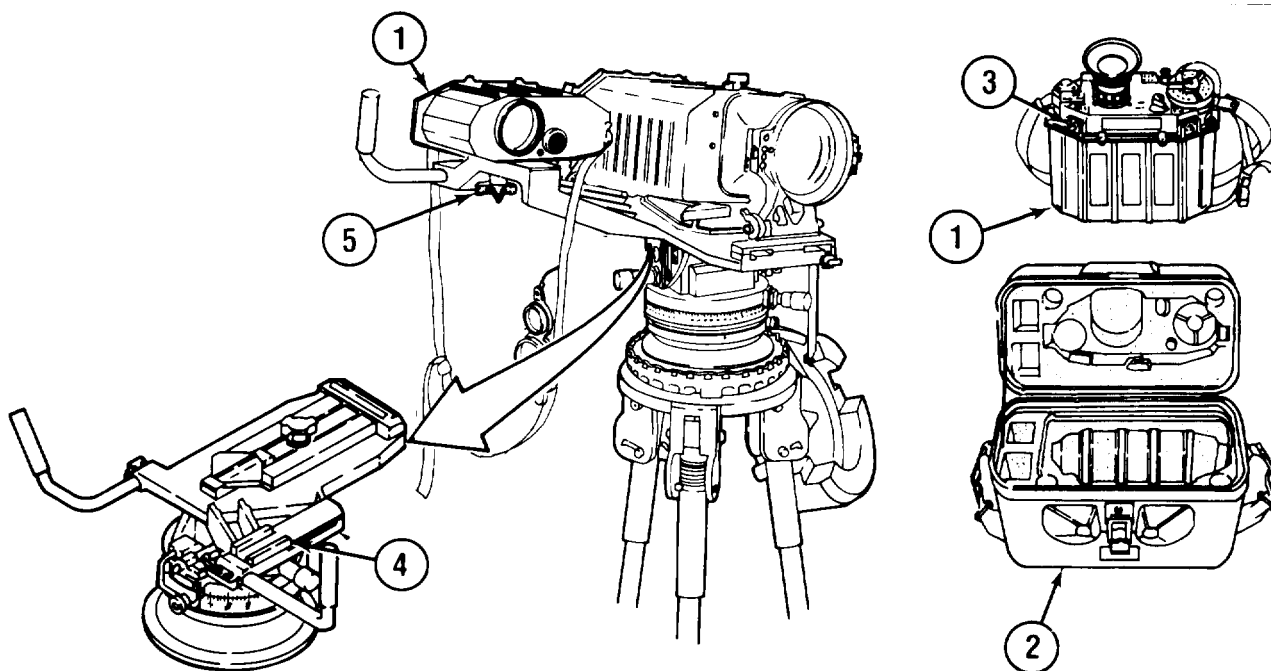

A. Remove AN/GVS-5 (1) from its case (2).



Do not touch FIRE button (3) on the AN/GVS-5 (1) until ready to range a target. Do not leave AN/GVS-5 (1) installed on APC mount assembly while vehicle is moving. Damage to the AN/GVS-5 (1) will result.

B. Align mounting plate on bottom of AN/GVS-5 (1) with the traverse head assembly V-way (4).

C. Align captive screw (5) in V-way (4) with threaded hole on bottom of AN/GVS-5 (1).



Insure captive screw (5) in V-way (4) is not crossthreaded into AN/GVS-5 (1).

D. Engage and tighten the captive screw (5) to secure AN/GVS-5 (1) to traverse head assembly V-way (4).

END OF TASK

2-14. CONNECTING VEHICLE POWER CONDITIONER  
(Sheet 1 of 2)

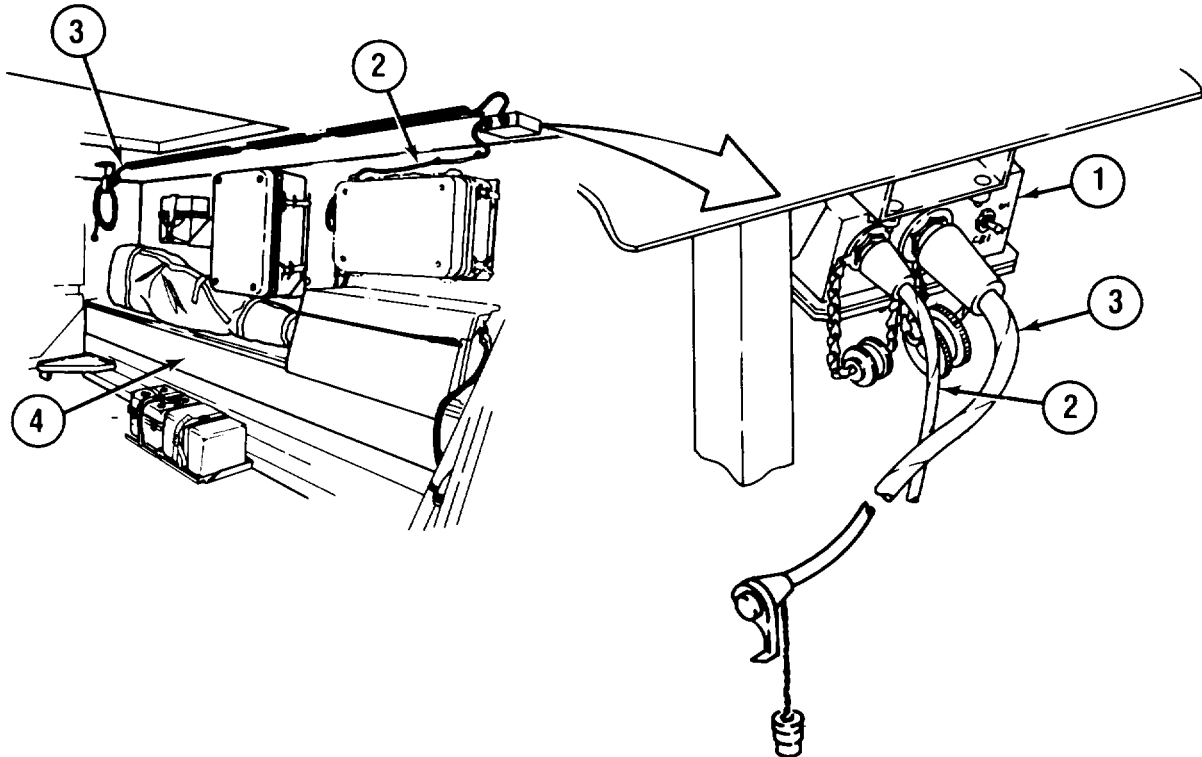
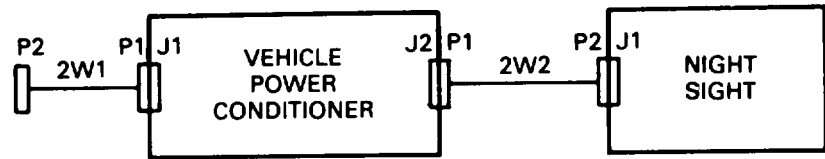

NOTE

Insure that vehicle power conditioner (1) cables 2W1 (2) and 2W2 (3) are connected to the vehicle power conditioner (1). Cable 2W1 (2) must be connected to the vehicle (4) power. Cable 2W2 (3) will be connected to the Night Sight by the following procedure.

GO TO NEXT PAGE

**2-14. CONNECTING VEHICLE POWER CONDITIONER (CONT)**  
**(Sheet 2 of 2)**

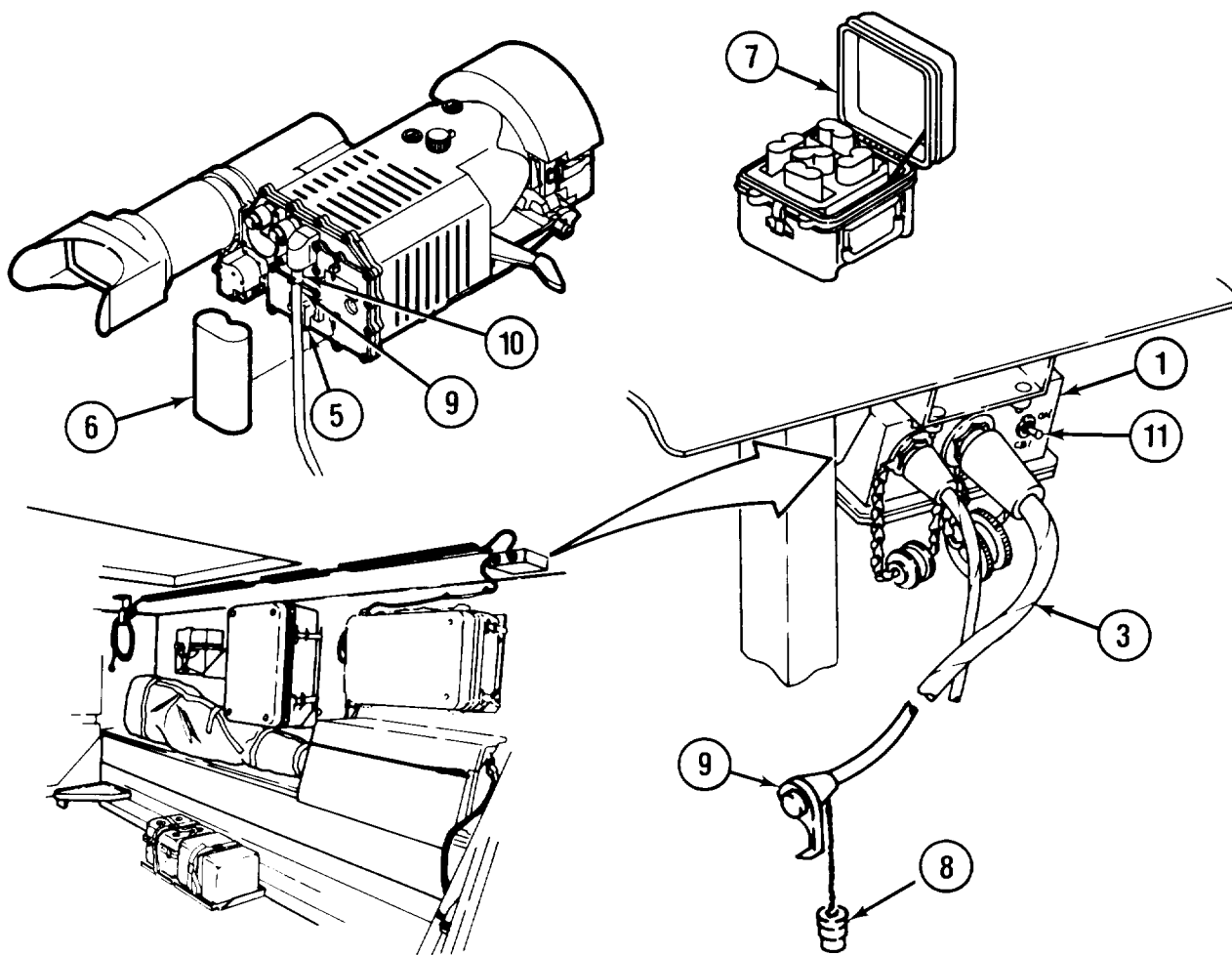

- A. Pull battery retainer (5) out to "open" position and remove battery (6) by pulling downward.
- B. Stow battery (6) in battery case (7).
- C. Remove cable 2W2 (3) connector P2 cover (8).
- D. Connect cable 2W2 (3) connector P2 (9) to Night Sight connector J1 (10).
- E. On vehicle power conditioner (1), set ON/OFF circuit breaker CB1 (11) to ON.

END OF TASK



## 2-15. INSTALLING BATTERY IN TRAVERSE HEAD ASSEMBLY

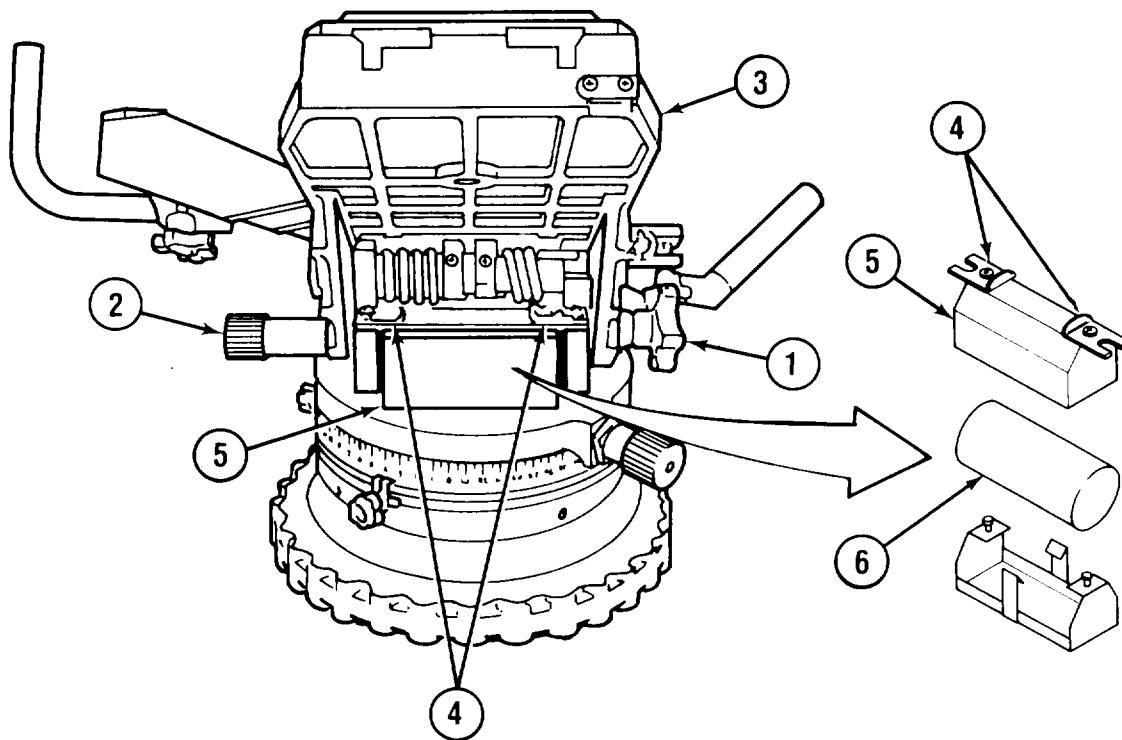

### STEP 1 REMOVAL

- A. Loosen elevation brake knob (1).
- B. Pull elevation stow knob (2).
- C. Tilt traverse head assembly (3) upward and tighten elevation brake knob (1).
- D. Release battery latches (4) and remove battery cover (5).
- E. Remove discharged battery (6).

### STEP 2 REPLACEMENT

- A. Install charged battery (6) (Item 1, Appendix D) and battery cove (5).
- B. Slide battery latches (4) to closed position.
- C. While supporting traverse head assembly (3), loosen elevation brake knob (1).
- D. Lower traverse head assembly (3) to horizontal position.

END OF TASK

## 2-16. CONNECTING RECHARGEABLE BATTERY TO NIGHT SIGHT

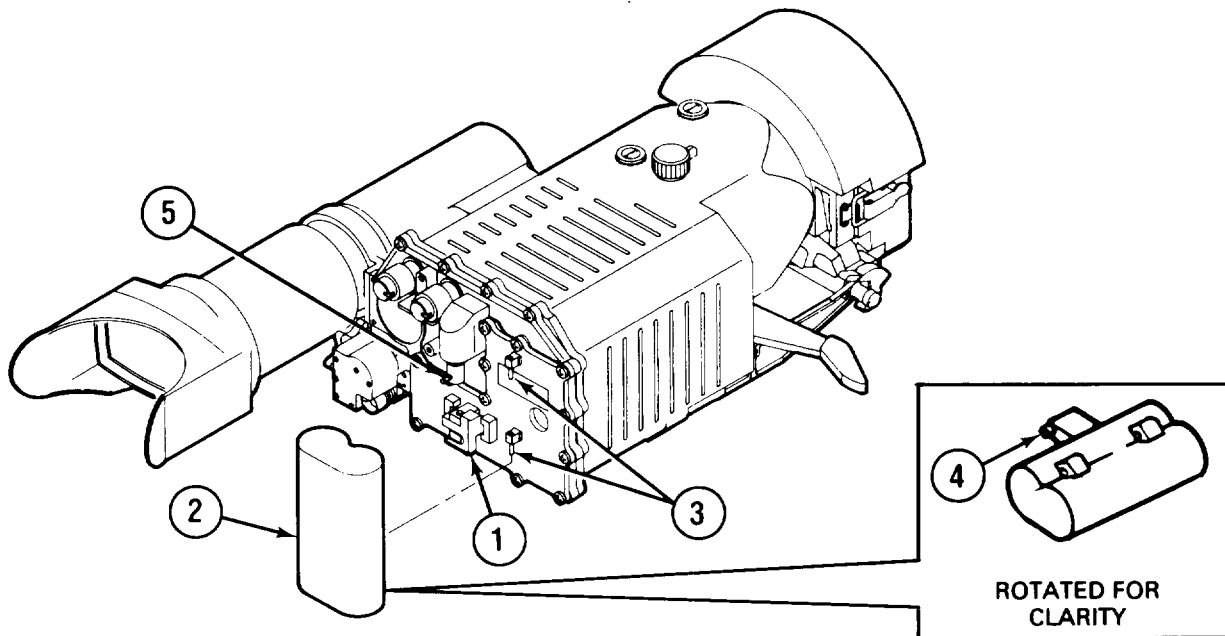

### STEP 1

### REMOVAL

- A. Pull battery retainer (1) to unlatched ("open") position.
- B. Move battery (2) downward off guide pins (3).

### STEP 2

### REPLACEMENT

- A. Align and move battery (2) upward onto guide pins (3).
- B. Engage battery connector (4) to Night Sight input power connector J1 (5).
- C. Move battery retainer (1) to latched ("closed") position.

END OF TASK

## 2-17. LEVELING PROCEDURE

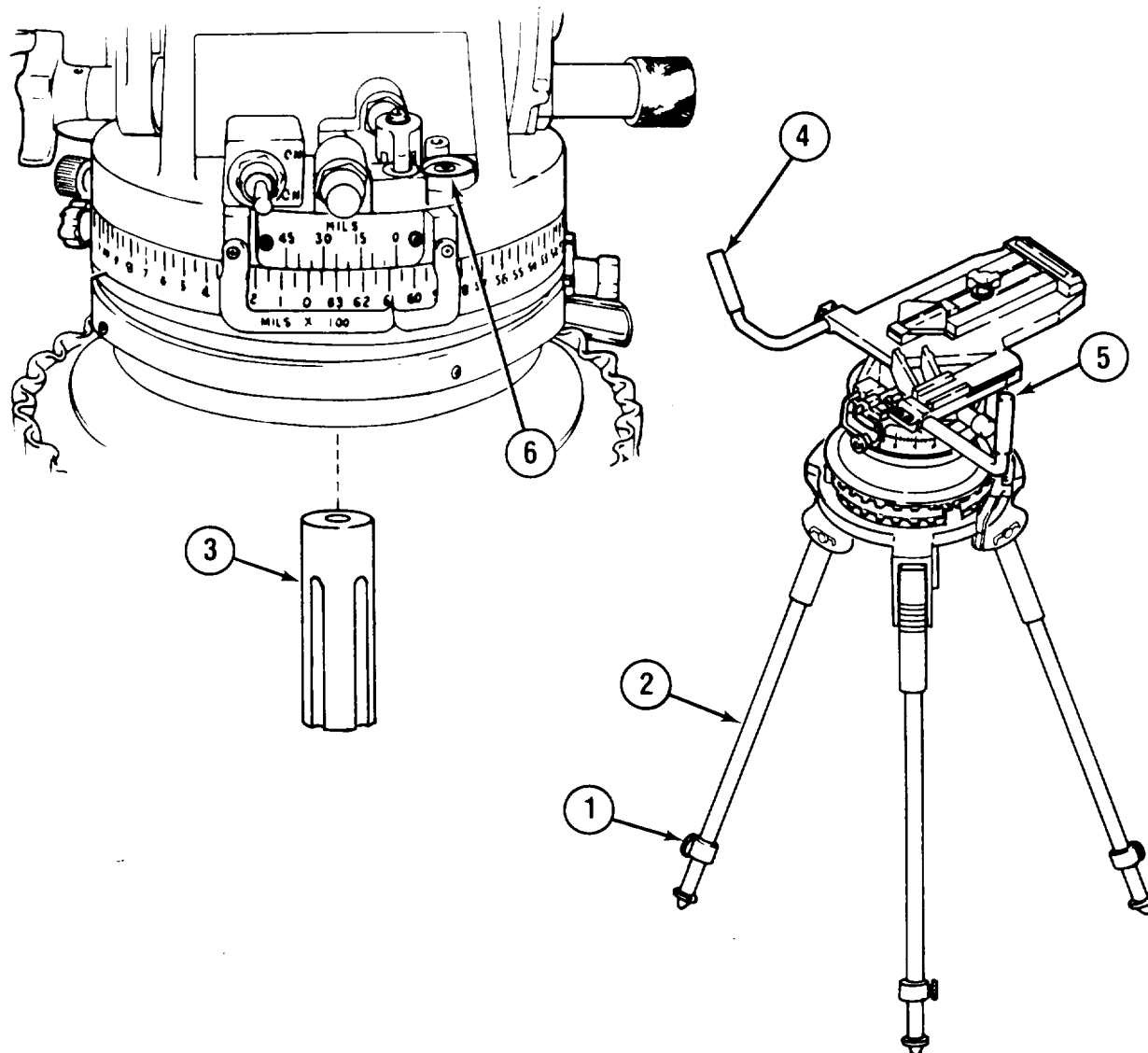

- A. Loosen leg release knobs (1) and adjust legs (2) to an approximately level position. Tighten leg release knobs (1).
- B. Loosen level lock handle (3).
- C. Hold handles (4) and (5) and center bubble in level (6).
- D. Tighten level lock handle (3).

END OF TASK

**2-18. COLLIMATING AN/GVS-5 TO NIGHT SIGHT**  
(Sheet 1 of 8)

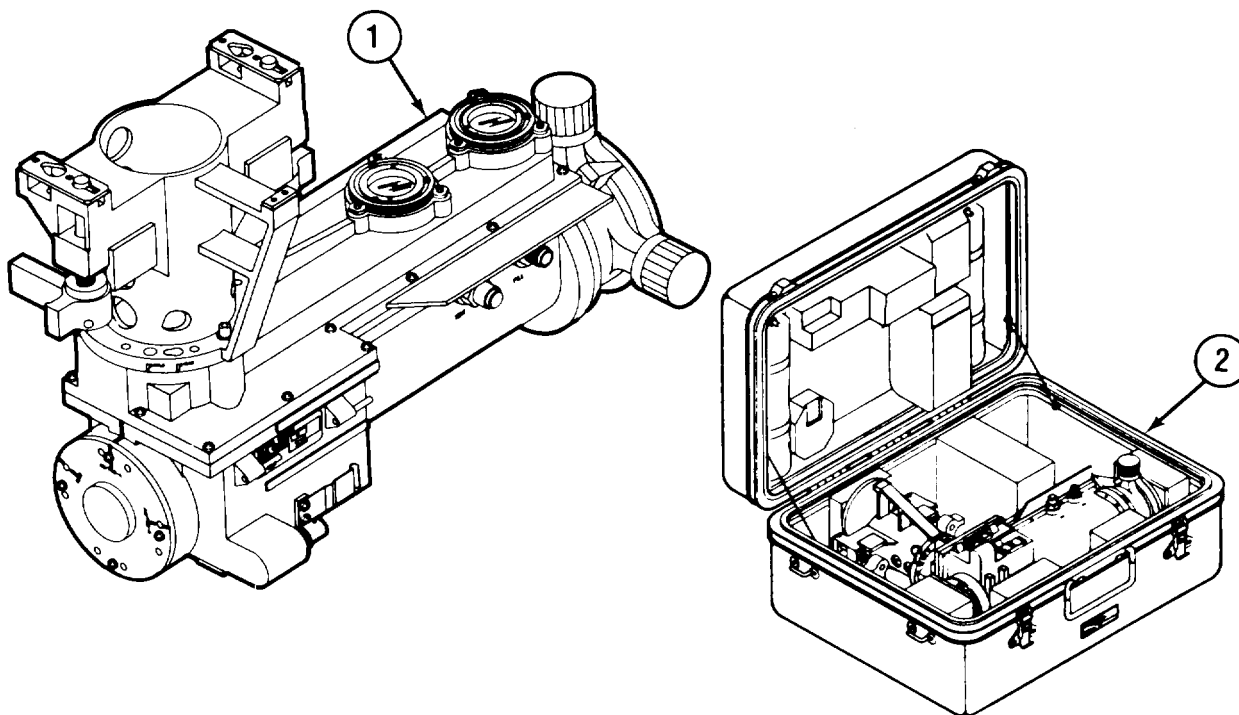

**CAUTION**

The Boresight Collimator (1) is a precision optical instrument and must be handled carefully. Do not drop.

NOTE

- Before each mission, after relocating, or when temperature changes more than 40° F, you must collimate the AN/GVS-5 to the Night Sight.
- Should the AN/GVS-5 fail to collimate to the Night Sight, replace the AN/GVS-5.

- A. Remove Boresight Collimator (1) from carrying case (2).
- B. Check that Boresight Collimator mount and controls are in AN/TAS-6 position.

GO TO NEXT PAGE

**2-18. COLLIMATING AN/GVS-5 TO NIGHT SIGHT (CONT)**  
**(Sheet 2 of 8)**

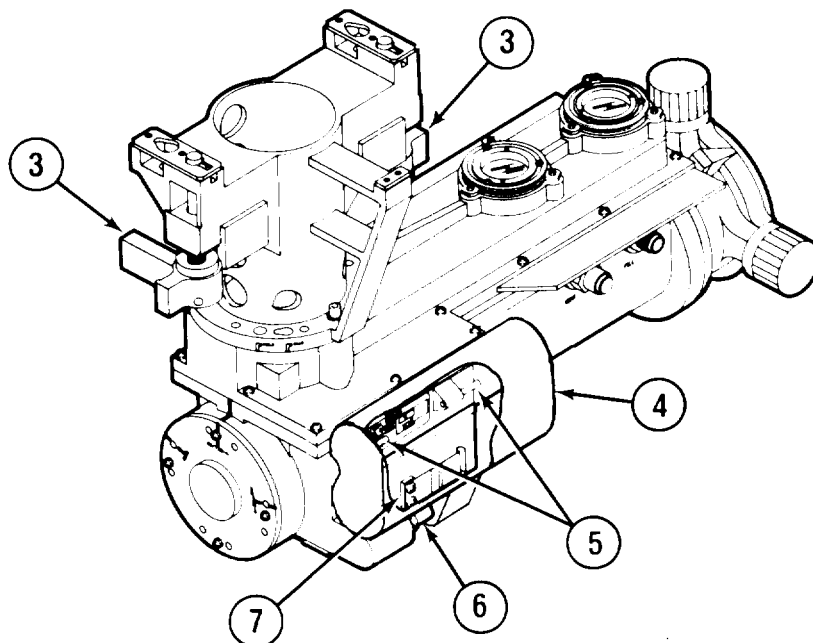

- C. Insure that Boresight Collimator mount latches (3) are in up position.
- D. Aline Boresight Collimator battery (4) with guide pins (5).
- E. Move battery onto guide pins (5) and engage connector (6).
- F. Insure that battery clip (7) engages battery (4).

GO TO NEXT PAGE

2-18. COLLIMATING AN/GVS-5 TO NIGHT SIGHT (CONT)  
(Sheet 3 of 8)

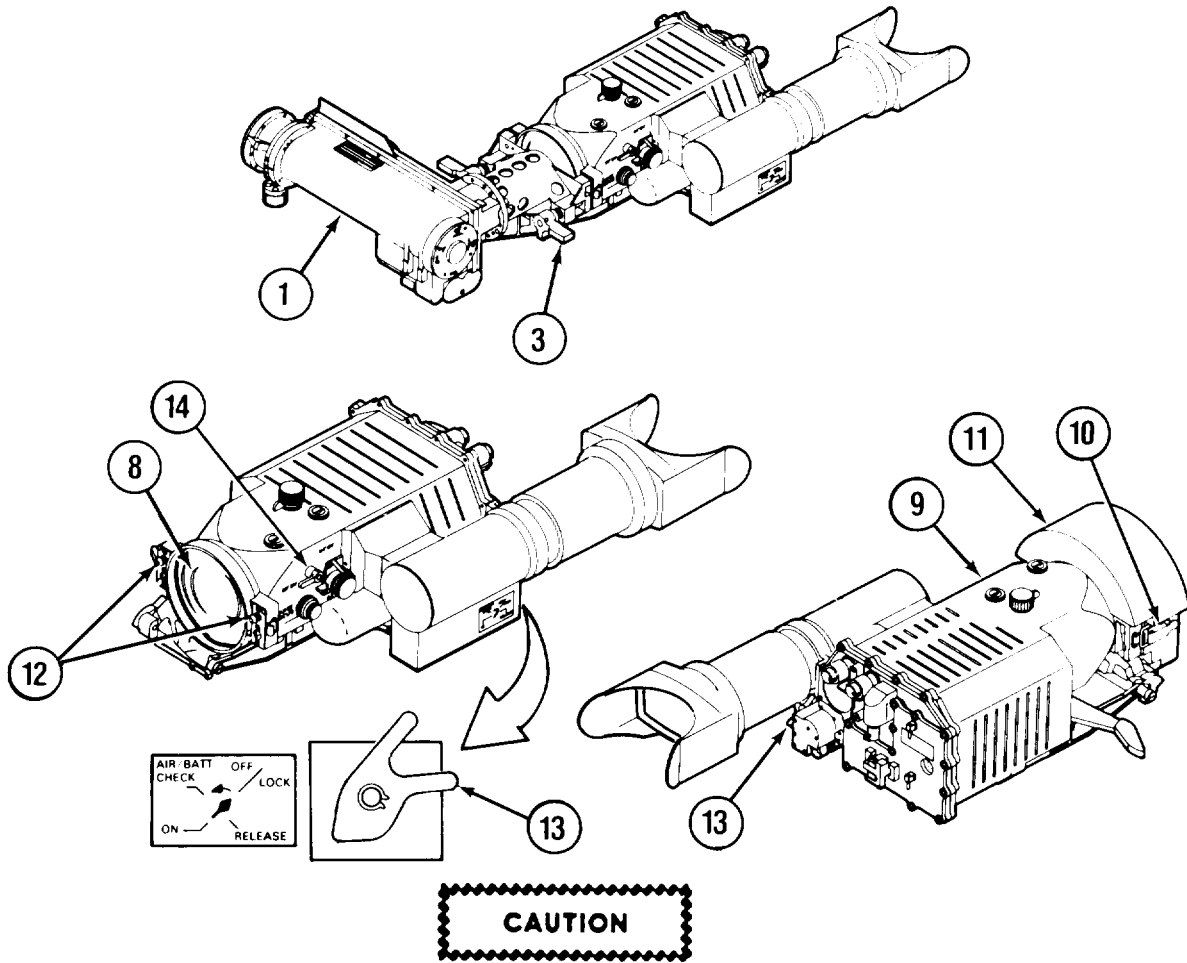

Insure that front Lens (8) of Night Sight (9) is not scratched.

- G. Release two latches (10) and remove afocal guard cushion (11) from Night Sight (9).
- H. Position Boresight Collimator (1) on locating pins (12) on front of Night Sight (9).
- I. Engage and secure Boresight Collimator latches (3) by pushing in and rotating latches (3).
- J. Insure that Night Sight actuator (13) is set to ON position.
- K. Insure that field-of-view switch (14) is set to NFOV.

GO TO NEXT PAGE

**2-18. COLLIMATING AN/GVS-5 TO NIGHT SIGHT (CONT)**  
**(Sheet 4 of 8)**

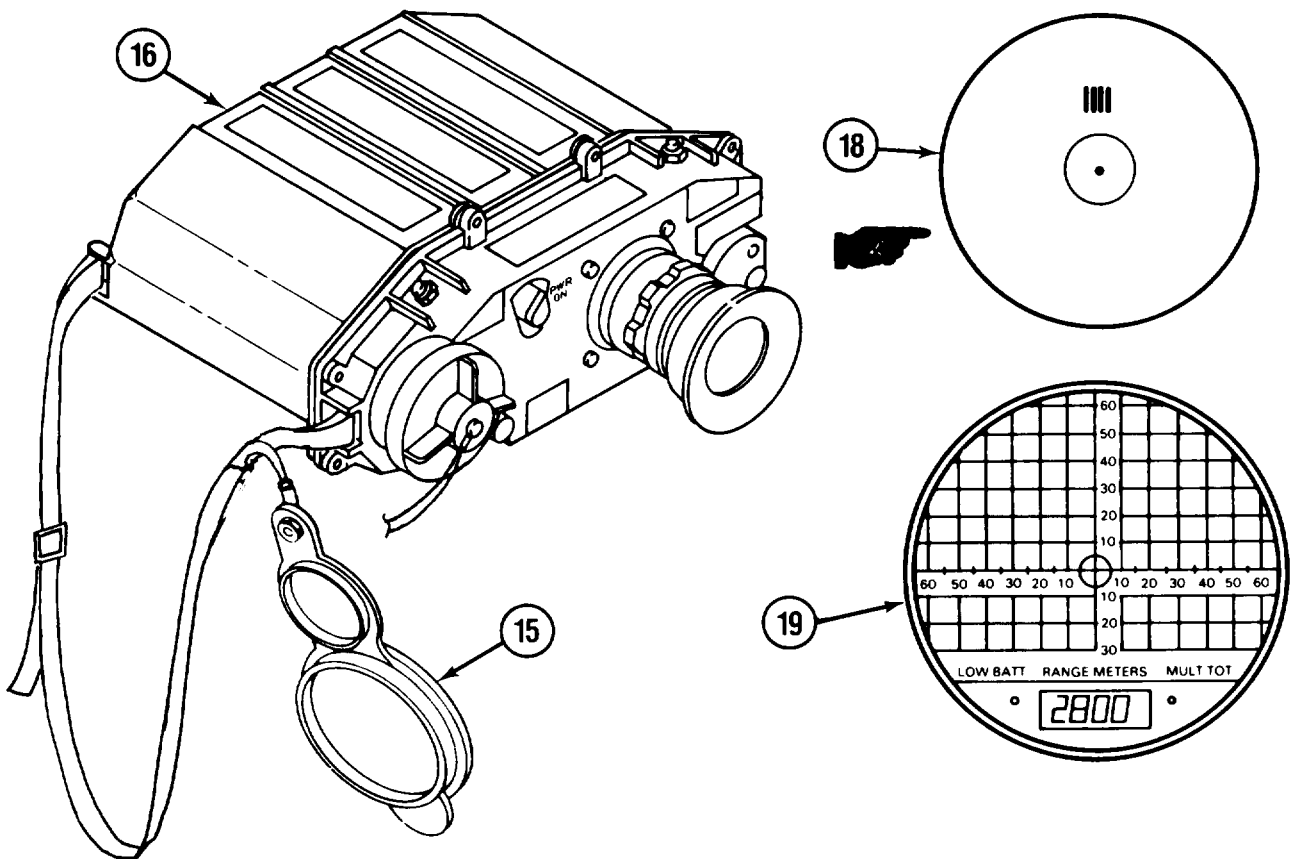

- L. Remove lens cover (15) from AN/GVS-5 (16).
- M. With AN/GVS-5 (16) operating normally, sight through AN/GVS-5 eyepiece (17).
- N. Adjust AN/GVS-5 eyepiece (17) for best reticle focus (18).
- O. Verify that Boresight Collimator reticle (18) and AN/GVS-5 reticle (19) are visible.

GO TO NEXT PAGE

2-18. COLLIMATING AN/GVS-5 TO NIGHT SIGHT (CONT)  
(Sheet 5 of 8)

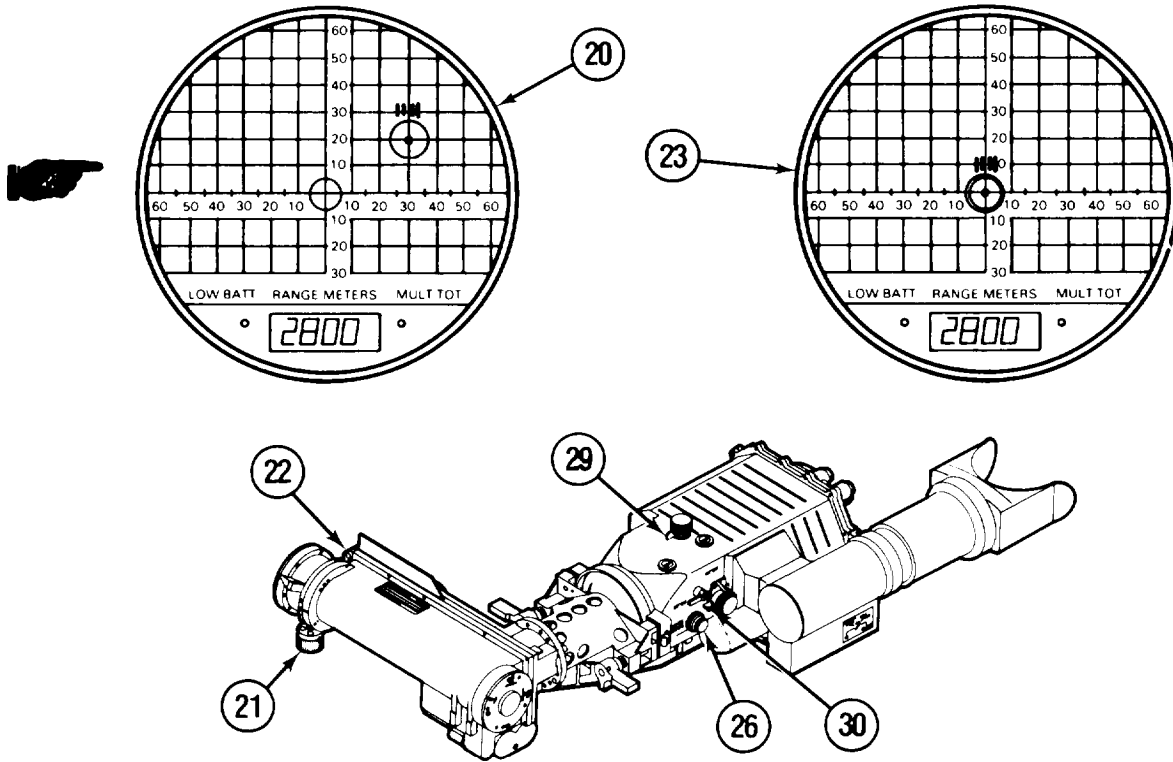

NOTE

While collimating, care should be taken not to put weight on AN/GVS-5 or right traversing handle. Added weight could cause a deflection of angle and give you a faulty indication.

- P. The two reticles (20) will be superimposed, one on the other. They will probably be out of alignment.
- Q. Adjust EL (21) and AZ (22) adjustment controls on Boresight Collimator to bring centers of the two reticles (20) into exact alignment (23).

GO TO NEXT PAGE



2-18. COLLIMATING AN/GVS-5 TO NIGHT SIGHT (CONT)  
(Sheet 6 of 8)

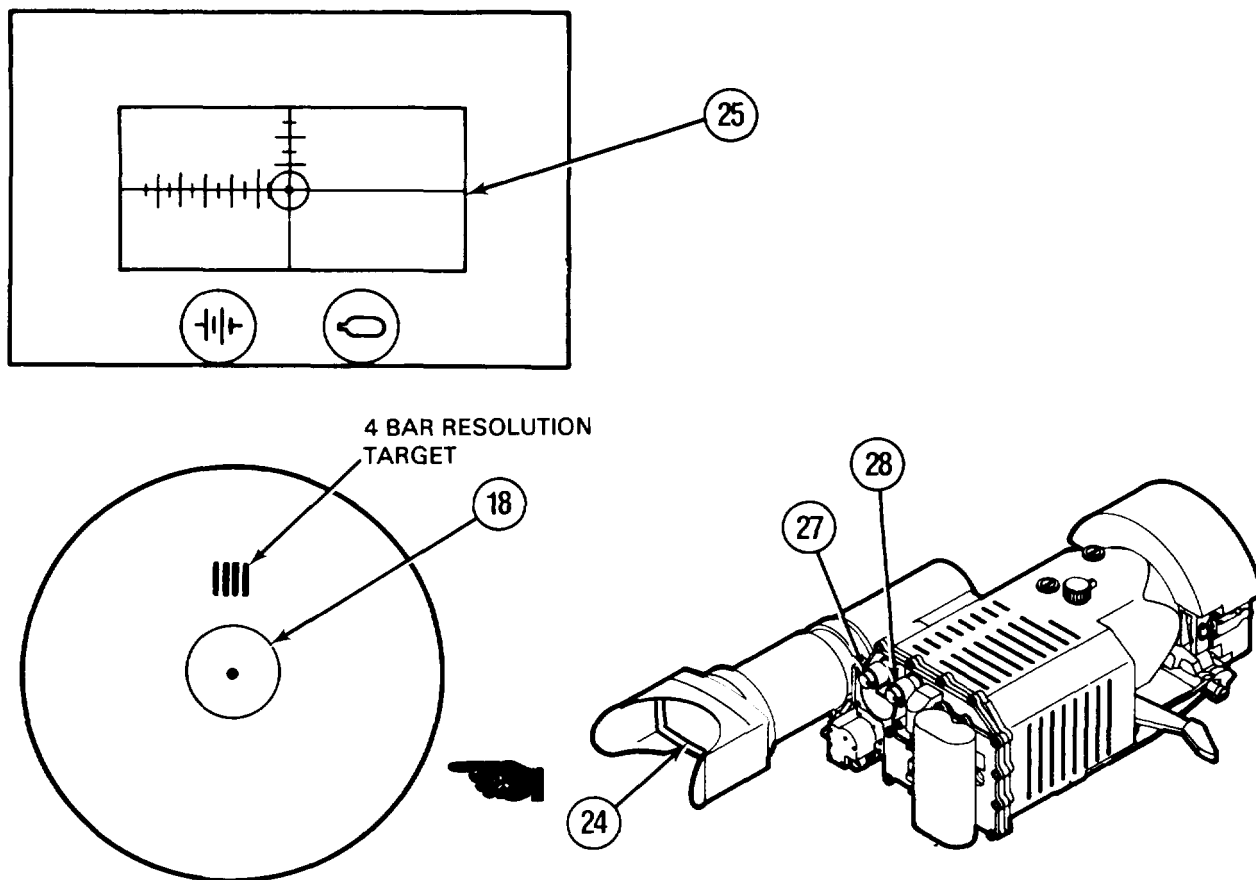

- R. Sight through Night Sight eyepiece (24). Night Sight reticle (25) and Boresight Collimator reticle (18) should both appear in the display.
- S. Adjust Night Sight RANGE FOCUS (26), BRT (27), and CTRS (28) controls as necessary for best view of Boresight Collimator reticle (18).
- T. Release EL (29) and AZ (30) adjustment locks.

GO TO NEXT PAGE

**2-18. COLLIMATING AN/GVS-5 TO NIGHT SIGHT (CONT)**  
 (Sheet 7 of 8)

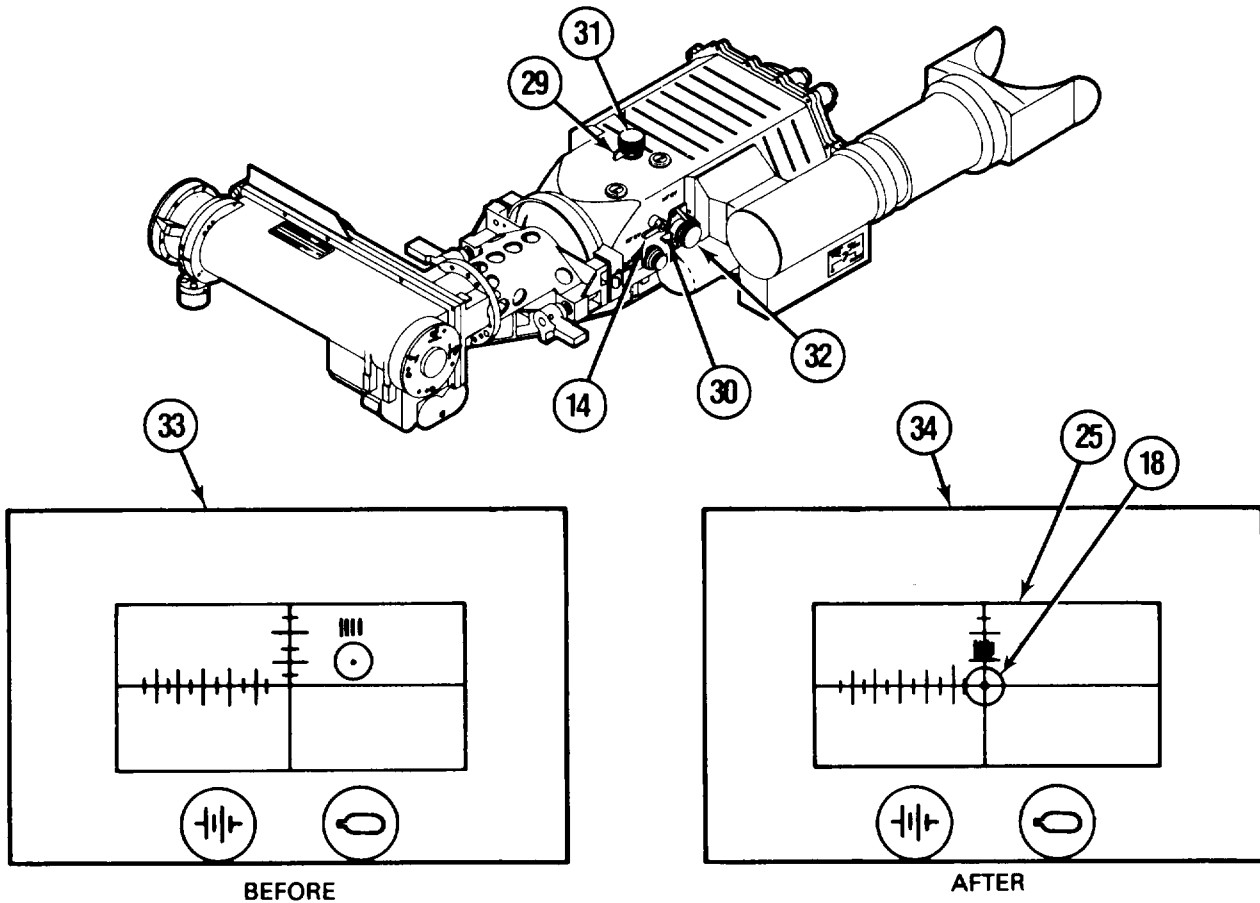

- U. Adjust EL (31) and AZ (32) boresight controls on the Night Sight to bring centers of reticles (33) into alignment (34).
- V. Set EL (29) and AZ (30) boresight locks to Locked position.

NOTE

Insure that Night Sight (9) is still in alignment with boresight reticle. Repeat steps T and U if necessary.

- W. Set Night Sight field-of-view switch (14) to WFOV.
- X. Adjust BRT (27) and CTRS (28) controls for best view of Boresight Collimator reticle (18).

GO TO NEXT PAGE

**2-18. COLLIMATING AN/GVS-5 TO NIGHT SIGHT (CONT)**  
(Sheet 8 of 8)

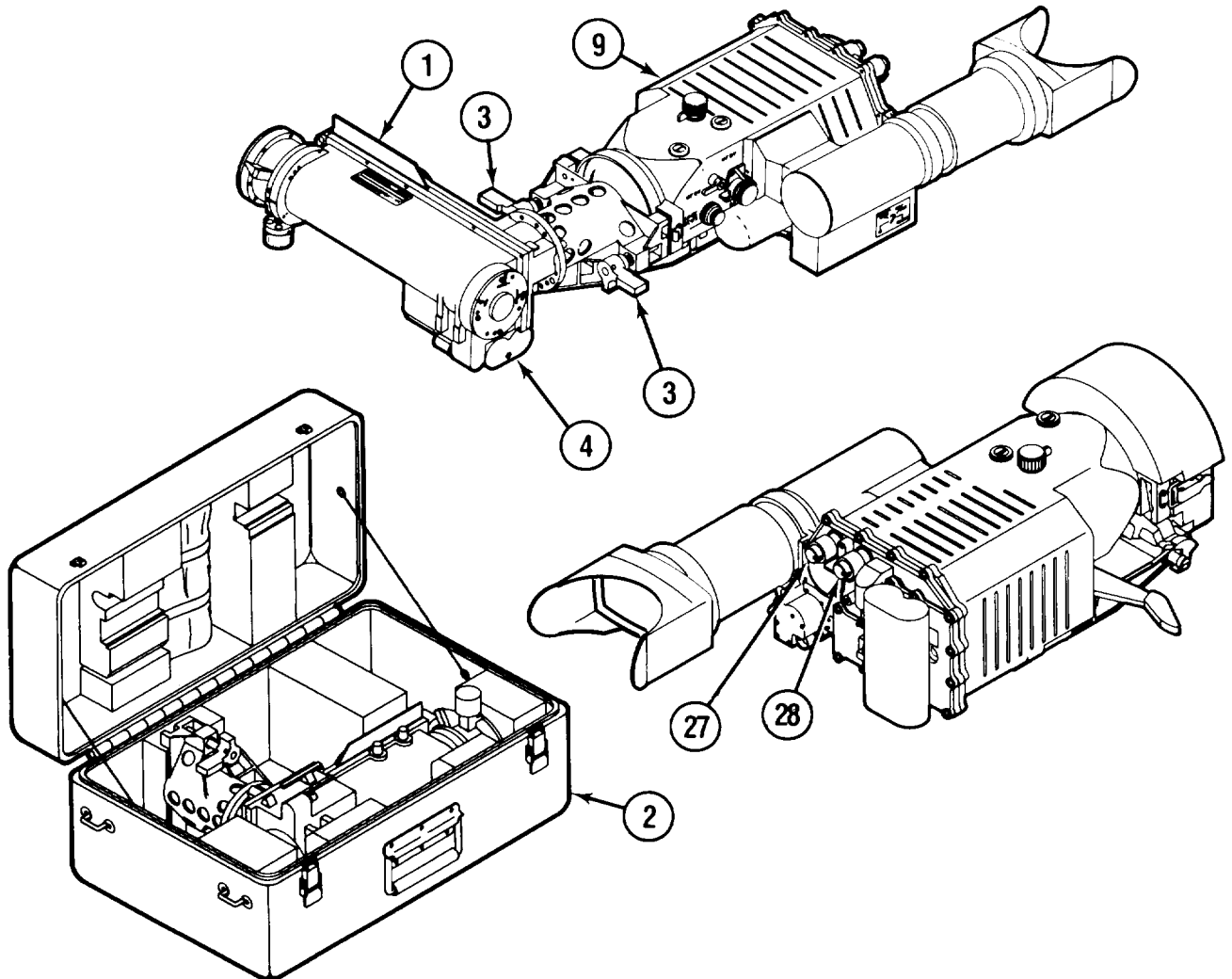

- Y. Insure Night Sight reticle (25) and Bore-sight Collimator reticle (18) remain aligned. Adjustment of BRT (27) and CTRS (28) may be necessary.
- Z. Remove Bore-sight Collimator (1) from Night Sight (9) by firmly holding unit and releasing latches (3).
- AA. Remove battery (4) from Bore-sight Collimator (1) (para 3-5).
- AB. Place Bore-sight Collimator (1) in carrying case (2).
- AC. If Night Sight is not to be used immediately, install afocal guard cushion.

END OF TASK

## Section IV. OPERATION UNDER USUAL CONDITIONS

SECTION CONTENTS	PARA	PAGE
SCOPE	2-19	2-44
OPERATION	2-20	2-45
STANDBY OPERATION	2-21	2-51
NIGHT SIGHT SHUTDOWN PROCEDURE	2-22	2-52
BORESIGHT COLLIMATOR OPTICS CLEANING PROCEDURE	2-23	2-57

### 2-19. SCOPE

Section IV contains the usual operation, standby operation, and shutdown procedures for the Night Sight with the AN/GVS-5. A Boresight Collimator optics cleaning procedure is also provided.

#### NOTE

Initial setup or relocating the AN/UAS-11 equipment set requires collimating the system.

2-20. OPERATION  
(Sheet 1 of 6)

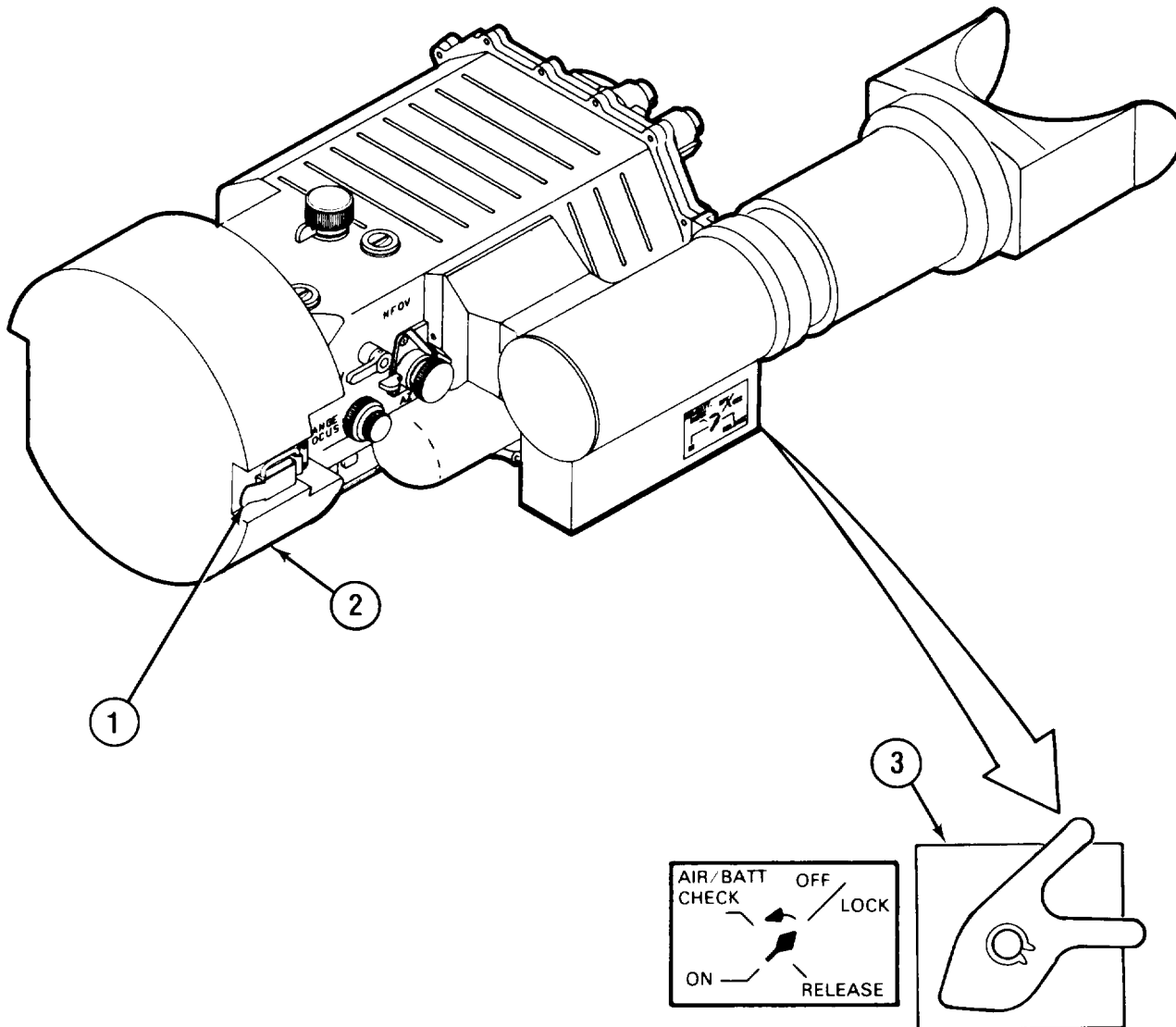

- A. Release two latches (1) and remove a focal guard cushion (2).
- B. Turn actuator (3) to ON position.

GO TO NEXT PAGE

2-20. OPERATION (CONT)  
(Sheet 2 of 6)

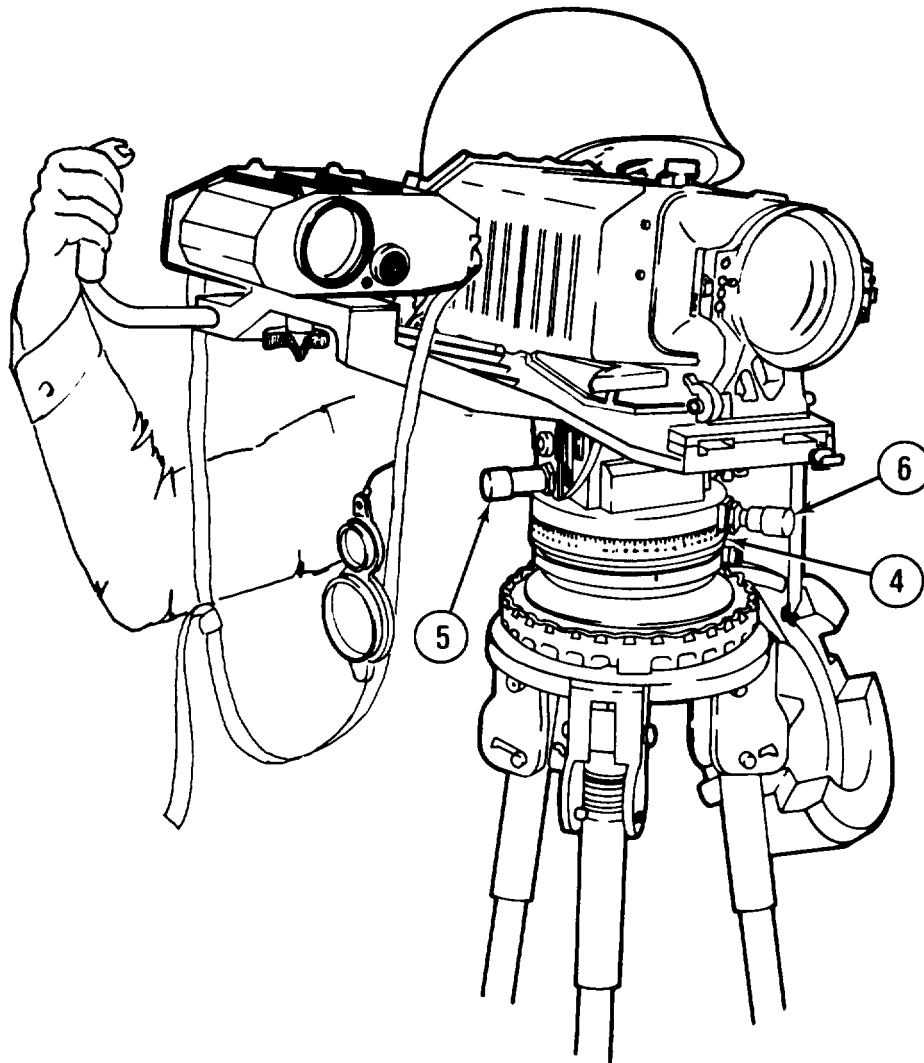

NOTE

Before each mission, or when temperature changes more than 40°F, you must collimate the AN/GVS-5 to the Night Sight.

- C. Select target area to be observed. To release traverse head assembly (4) from stow position, pull out azimuth (5) and elevation (6) lock knobs and turn each knob 1/4-turn.

GO TO NEXT PAGE

## 2-20. OPERATION (CONT) (Sheet 3 of 6)

---

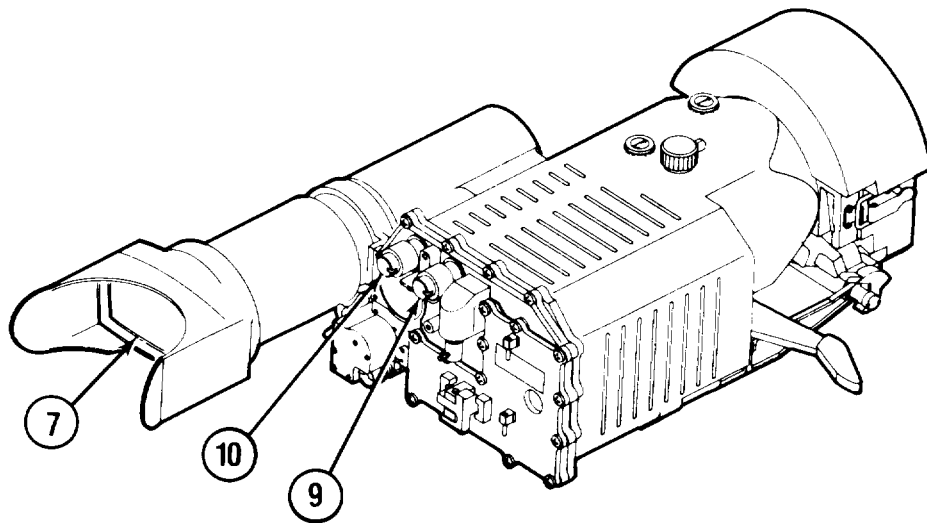
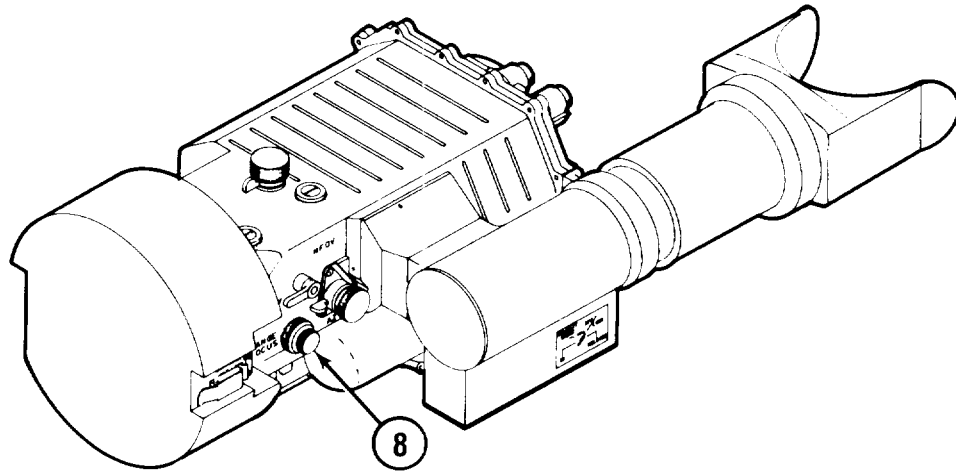

- D. Select a scene and looking through eyepiece (7), adjust RANGE focus (8).
- E. Adjust CTRS (9) and BRT (10) controls for best image.

GO TO NEXT PAGE

2-20. OPERATION (CONT)  
(Sheet 4 Of 6)

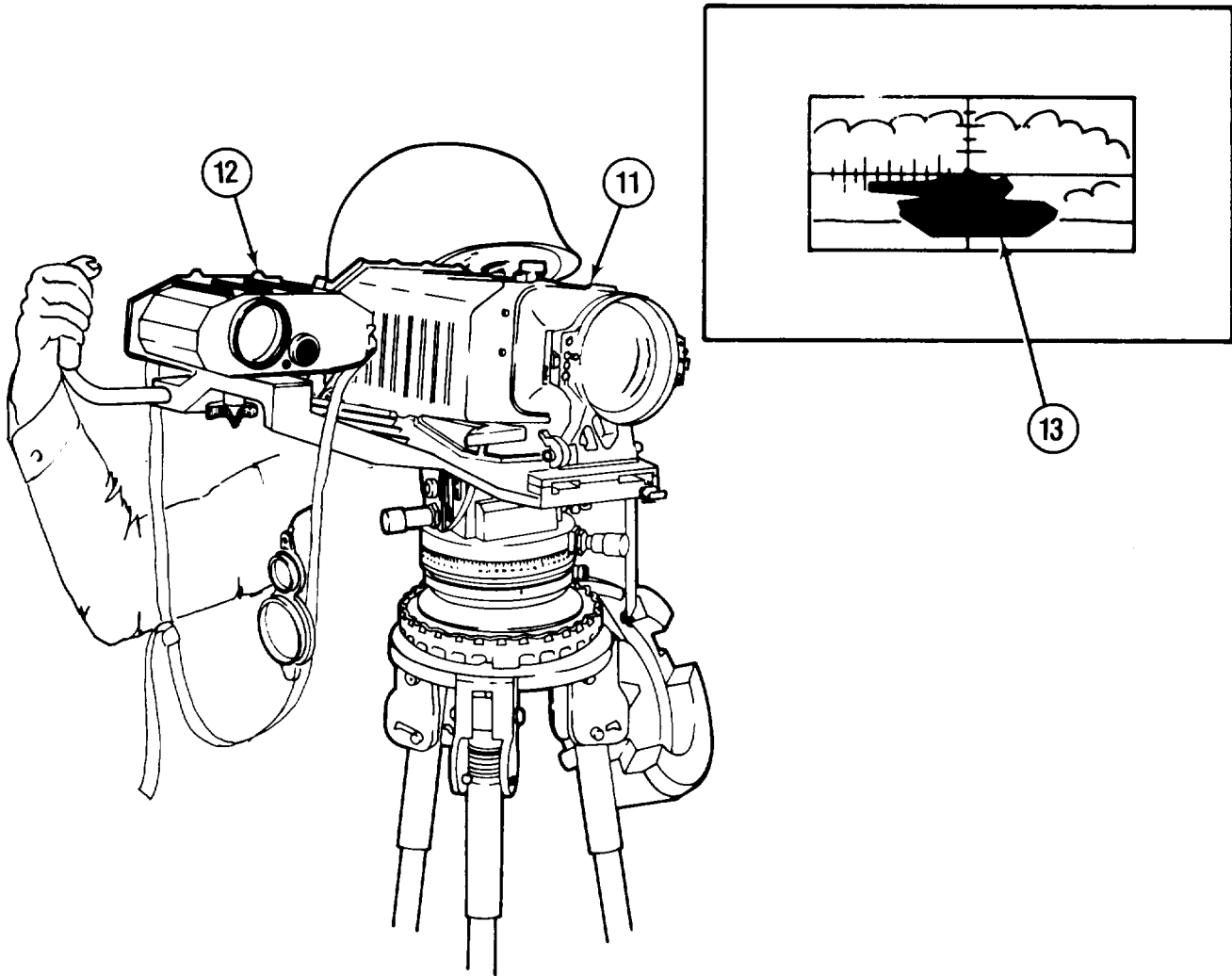

F. Use Night Sight (11) with AN/GVS-5 (12) for observation and surveillance missions by sighting in on the top of the target (13).

GO TO NEXT PAGE



**2-20. OPERATION (CONT)**  
**(Sheet 5 of 6)**

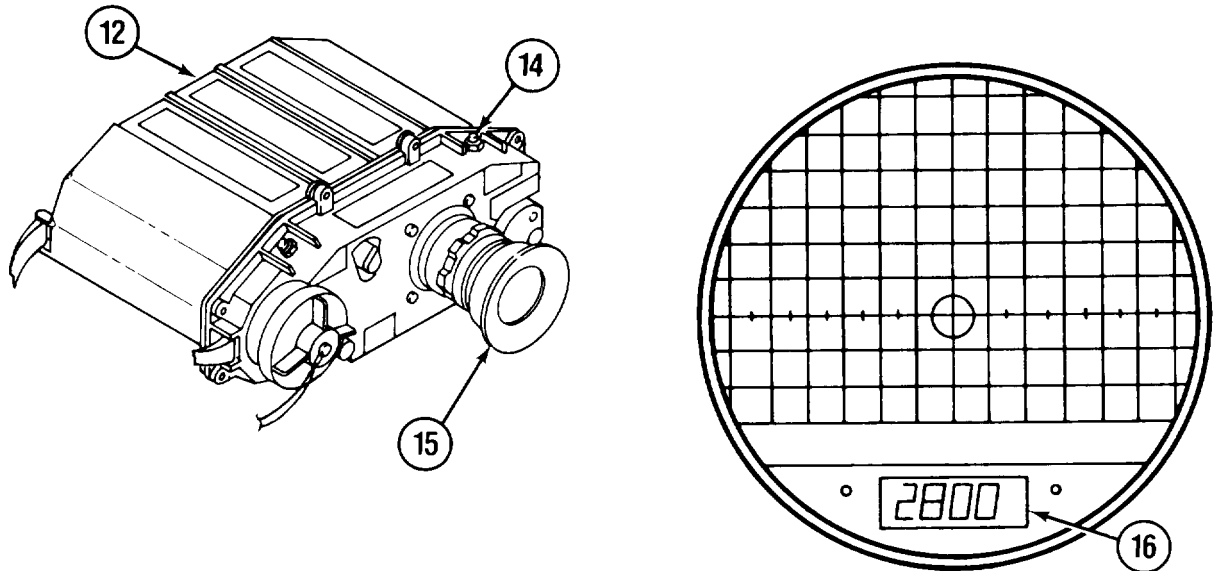

NOTE

When triggering the AN/GVS-5 (12), care should be taken not to put weight on AN/GVS-5 or right traversing handle. Added weight could cause a deflection of angle and give you a faulty indication.

- G. On AN/GVS-5 (12), press FIRE button (14) then look into AN/GVS-5 eyepiece (15) and read distance (16) to target at bottom of reticle.

GO TO NEXT PAGE

2-20. OPERATION (CONT)  
(Sheet 6 of 6)

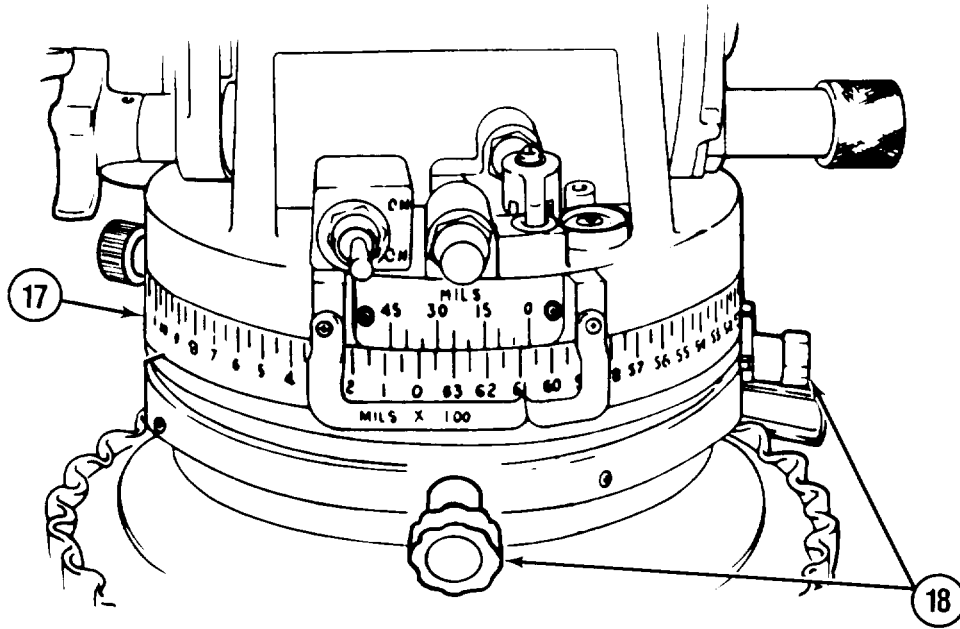

- H. To establish a reference point by moving azimuth scale drum (17), unscrew both detent knobs (18).
- I. Rotate azimuth scale drum (17) to desired position and tighten both detent knobs (18).
- J. To store in Night Sight position, unscrew one detent knob (18). Move knob (18) under vernier scale until knob (18) clicks into space, and tighten detent knob (18).

END OF TASK

## 2-21. STANDBY OPERATION

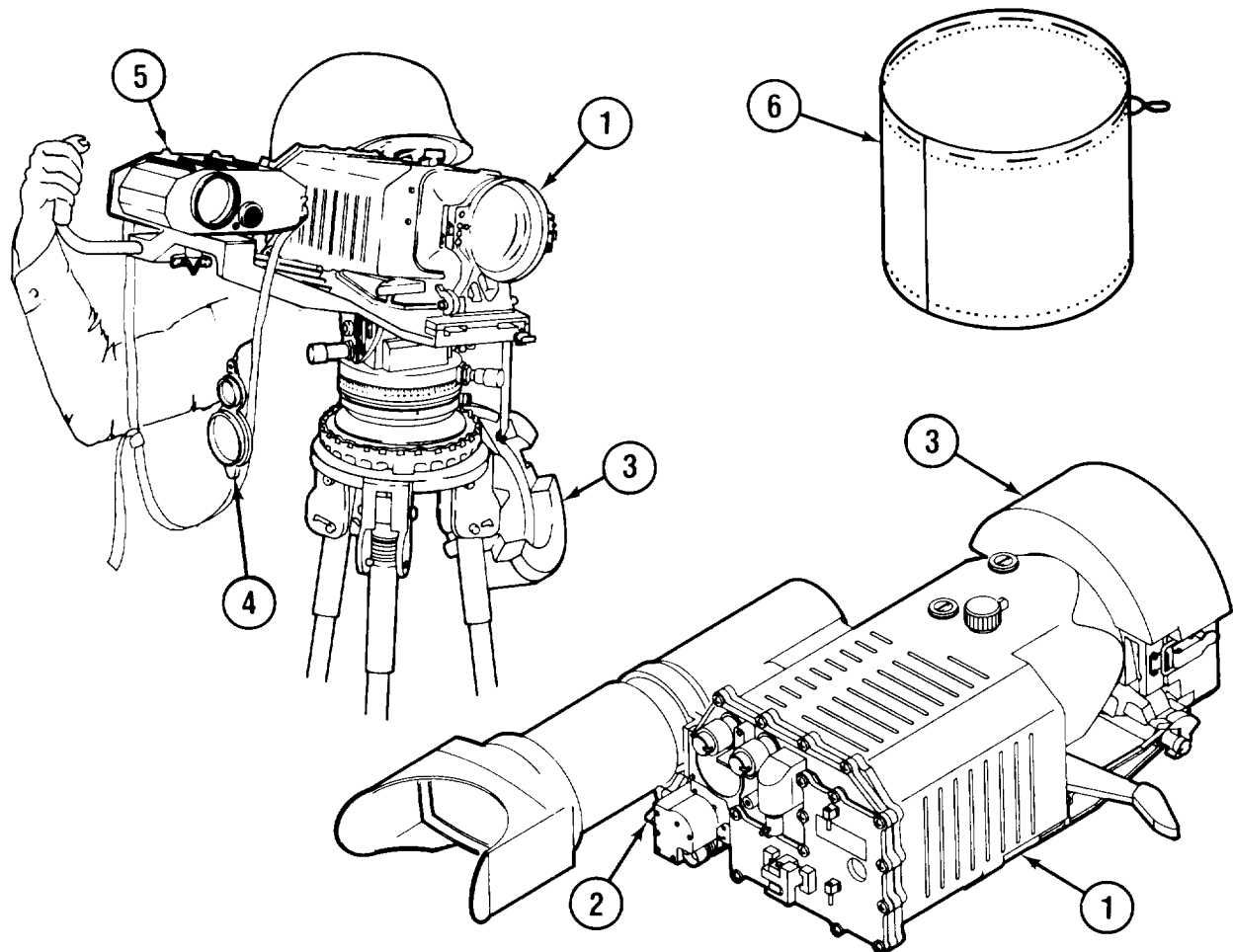

- A. On Night Sight (1), set actuator (2) to OFF/LOCK position.
- B. Install afocal guard cushion (3) on Night Sight (1).
- C. Install lens cap (4) on AN/GVS-5 (5).
- D. Install equipment cover (6).

**2-22. NIGHT SIGHT SHUTDOWN PROCEDURE**  
**(Sheet 1 of 5)**

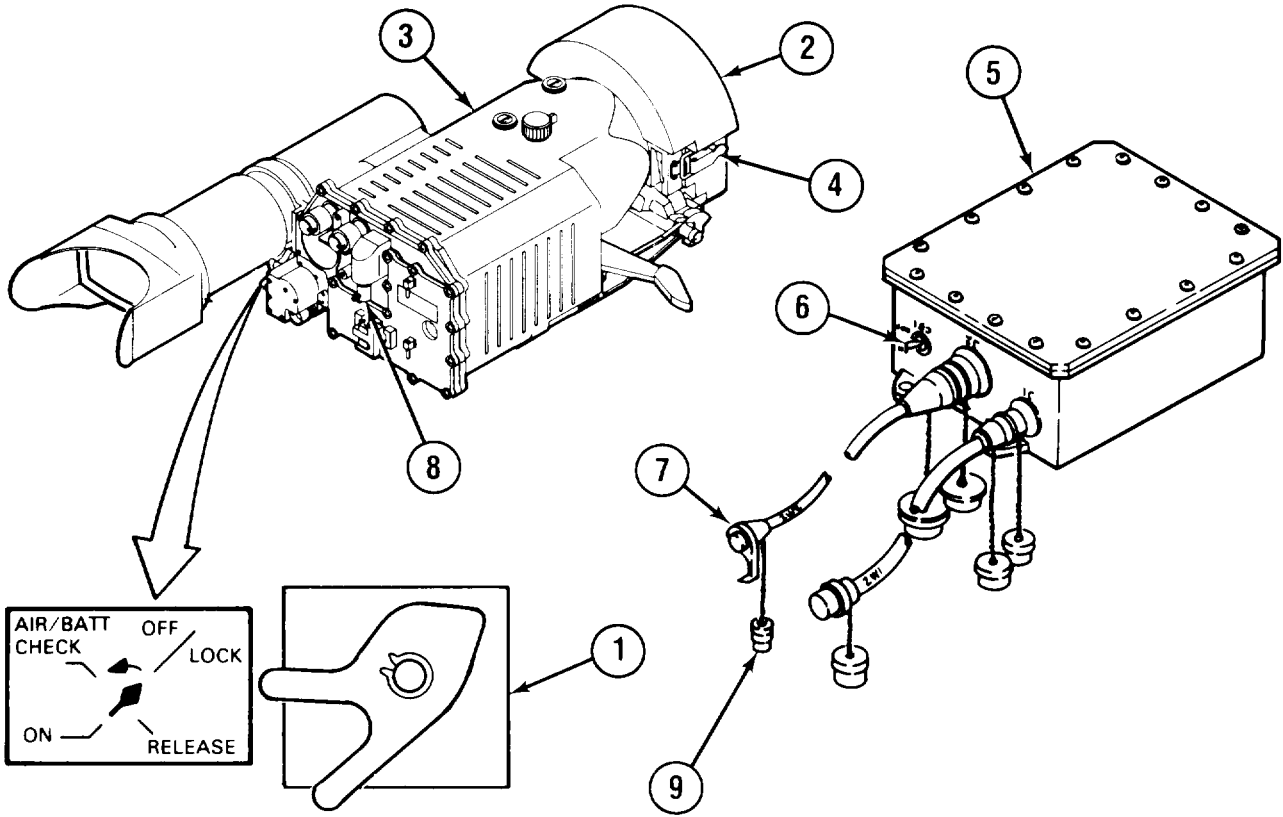

- A. Set Night Sight actuator (1) to OFF/LOCK position.
- B. Install afocal guard cushion (2) on Night Sight (3) and secure latches (4).
- C. If Night Sight (3) was used with vehicle power conditioner (5), set circuit breaker CB1 (6) to OFF.
- D. Disconnect cable 2W2 connector P2 (7) from Night Sight input power connector J1 (8).
- E. Install connector cover (9) on cable 2W2 connector P2 (7).
- F. Install Night Sight battery (para 3-4).

GO TO NEXT PAGE

## 2-22. NIGHT SIGHT SHUTDOWN PROCEDURE (CONT) (Sheet 2 of 5)

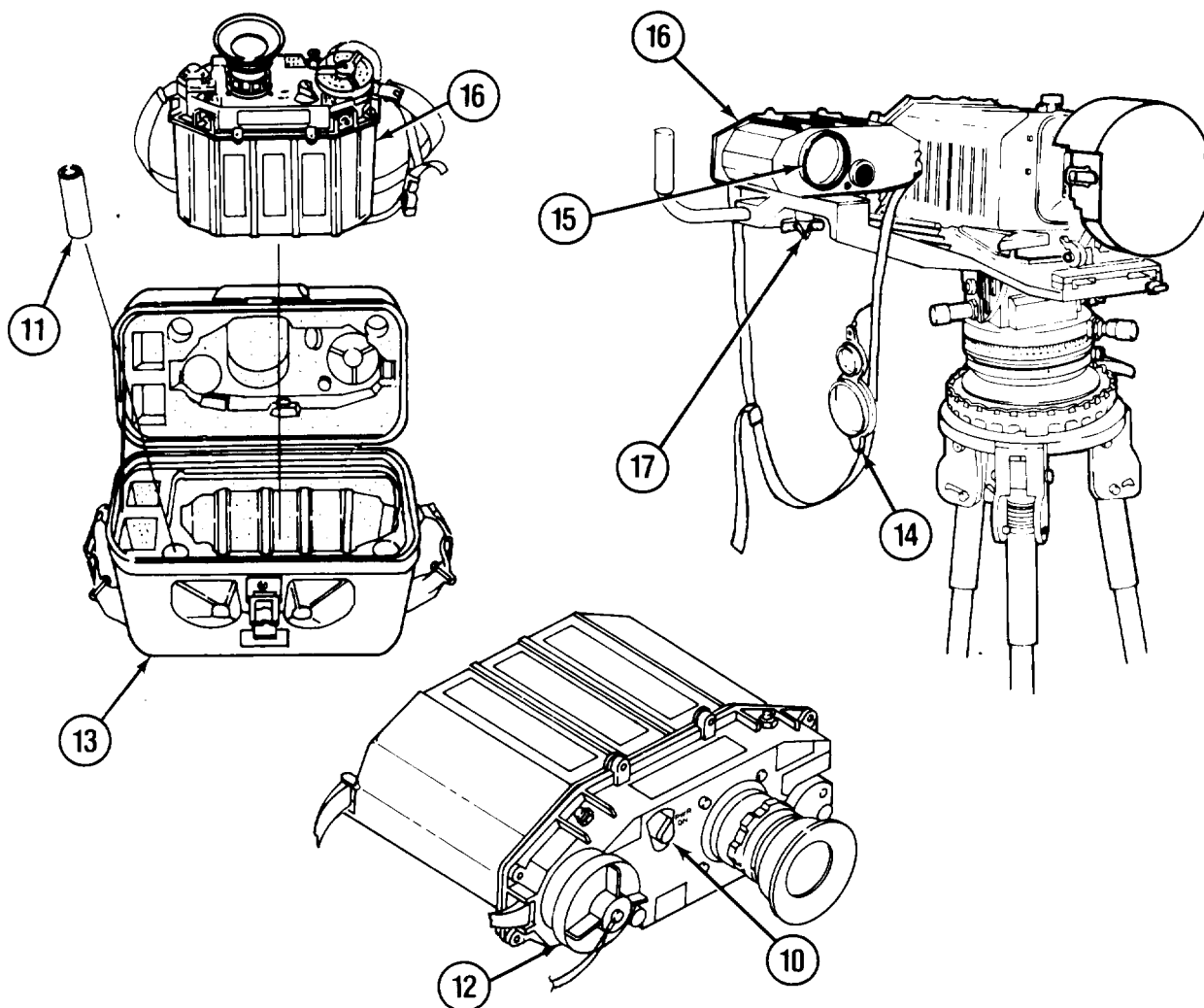

- G. Set AN/GVS-5 POWER switch (10) to OFF.
- H. Remove AN/GVS-5 battery (11) from battery compartment (12) and store in carrying case (13).
- I. Install cap (14) on AN/GVS-5 front lens (15).
- J. Supporting AN/GVS-5 (16) securely, loosen captive screw (17) and remove AN/GVS-5 (16).
- K. Place AN/GVS-5 (16) in carrying case (13).

GO TO NEXT PAGE

**2-22. NIGHT SIGHT SHUTDOWN PROCEDURE (CONT)**  
 (Sheet 3 of 5)

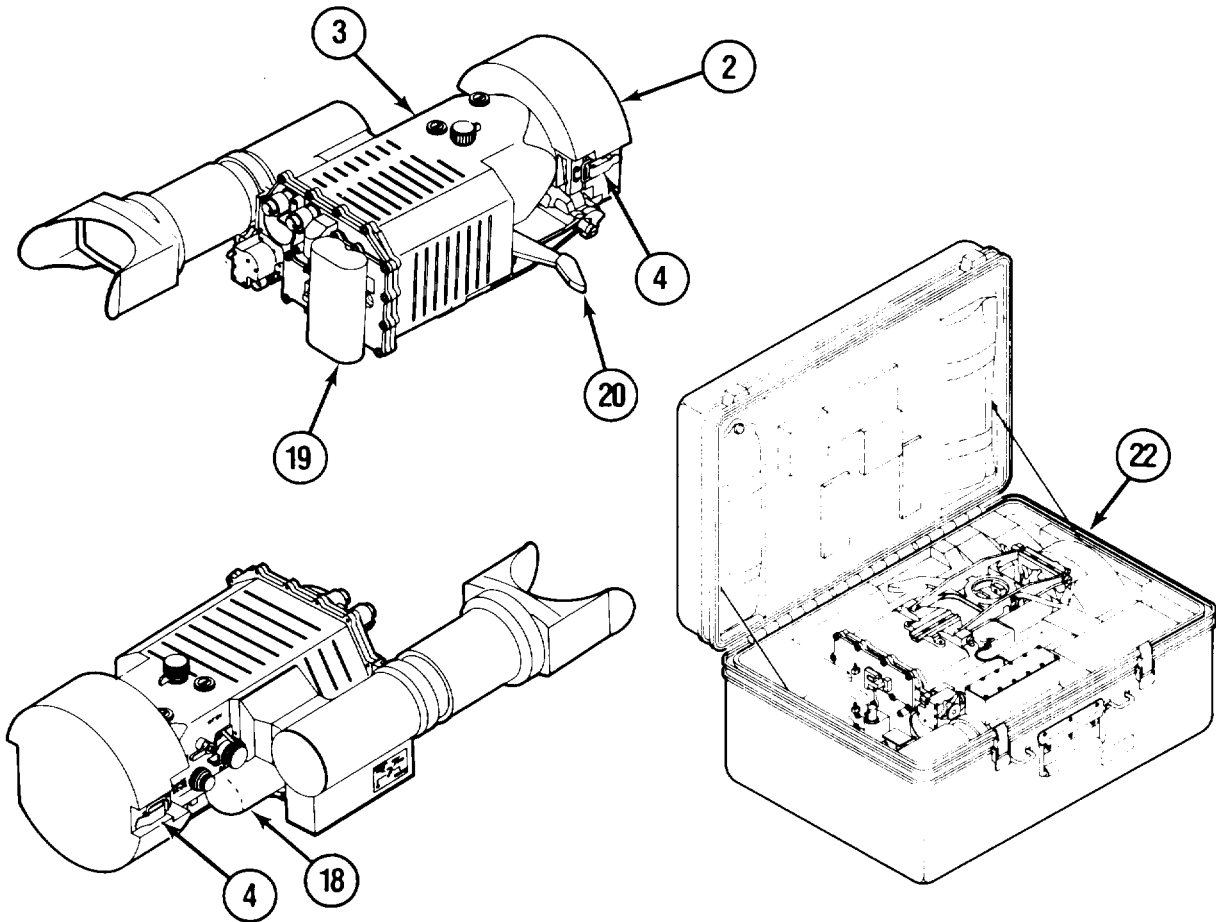

- L. Install afocal guard cushion (2) on Night Sight (3) and secure latches (4).
- M. Insure cooling cartridge (18) and battery (19) are installed on Night Sight (3).
- N. Support Night Sight (3) securely with left hand and move latch handle (20) rearward to the unlocked position.
- O. Remove Night Sight (3) from the traverse head assembly (21) .
- P. Turn Night Sight (3) over and secure in place in field handling case (22).

GO TO NEXT PAGE

## 2-22. NIGHT SIGHT SHUTDOWN PROCEDURE (CONT)

(Sheet 4 of 5)

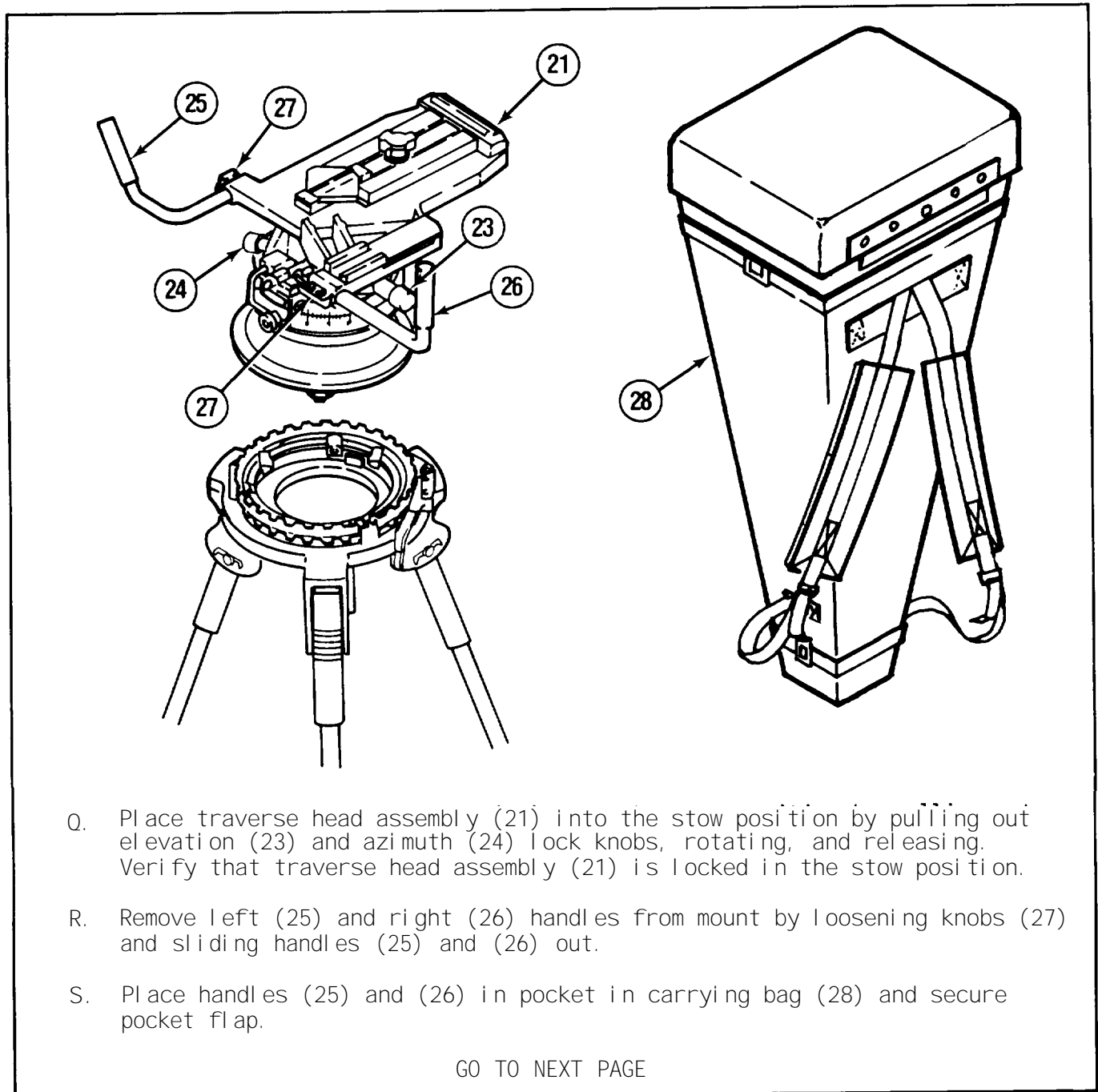

- Q. Place traverse head assembly (21) into the stow position by pulling out elevation (23) and azimuth (24) lock knobs, rotating, and releasing. Verify that traverse head assembly (21) is locked in the stow position.
- R. Remove left (25) and right (26) handles from mount by loosening knobs (27) and sliding handles (25) and (26) out.
- S. Place handles (25) and (26) in pocket in carrying bag (28) and secure pocket flap.

GO TO NEXT PAGE

**2-22. NIGHT SIGHT SHUTDOWN PROCEDURE (CONT)**  
**(Sheet 5 of 5)**

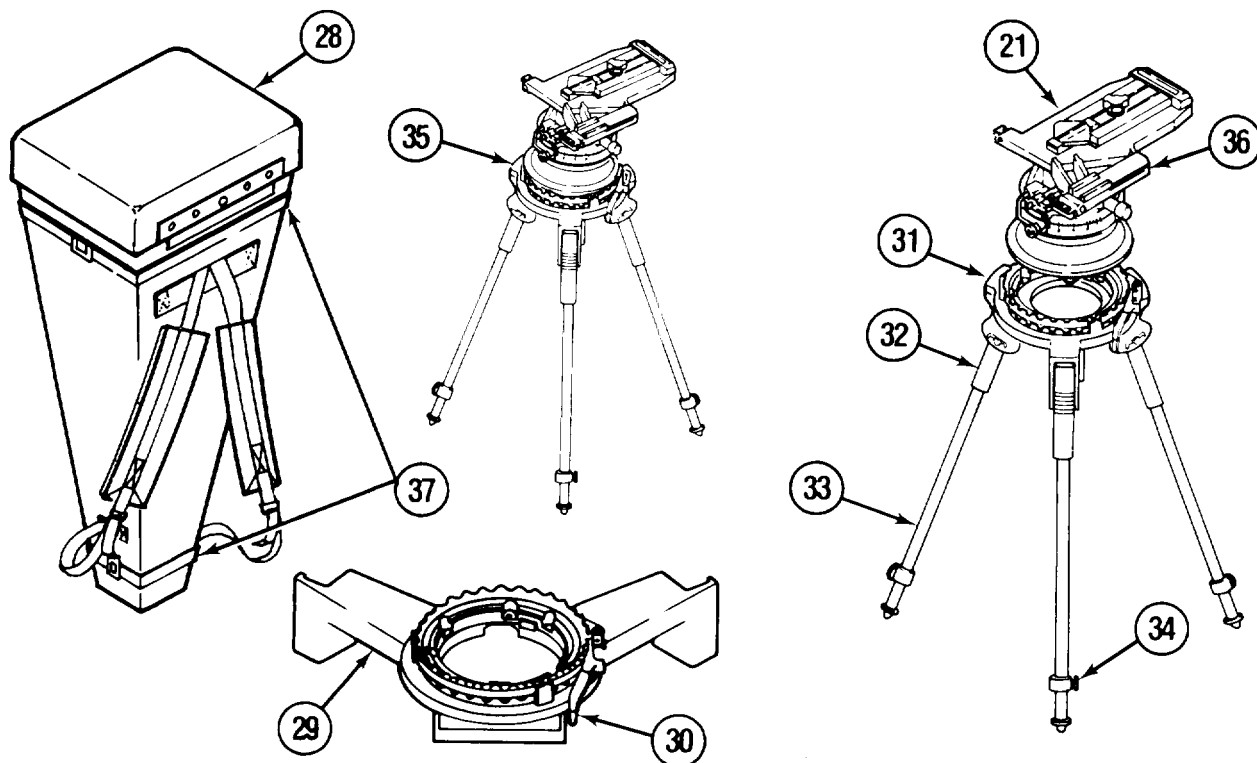

- T. If traverse head assembly (21) is installed on APC Mount Assembly (29), loosen modified clamp (30). Remove traverse head assembly (21) and install on leg assembly (31).
- U. Lift up leg assembly locking handles (32) and move legs (33) fully inward.
- V. Loosen leg release knobs (34) and allow legs (33) to retract to stow position and tighten leg release knobs (34).
- W. Stow Tripod (35) in carrying bag (28). Verify that Tripod (35) is properly oriented in bag (28) and is secure.

NOTE

AN/GVS-5 mounting base (36) is oriented with indentation in carrying bag cover (28).

- X. Secure tie-down straps (37) around carrying bag (28).

END OF TASK



**2-23. BORESIGHT COLLIMATOR OPTICS CLEANING PROCEDURE****TOOLS:**

None

**EQUIPMENT CONDITION:**

Assembled

**MATERIALS:**

Lens Cleaning Kit

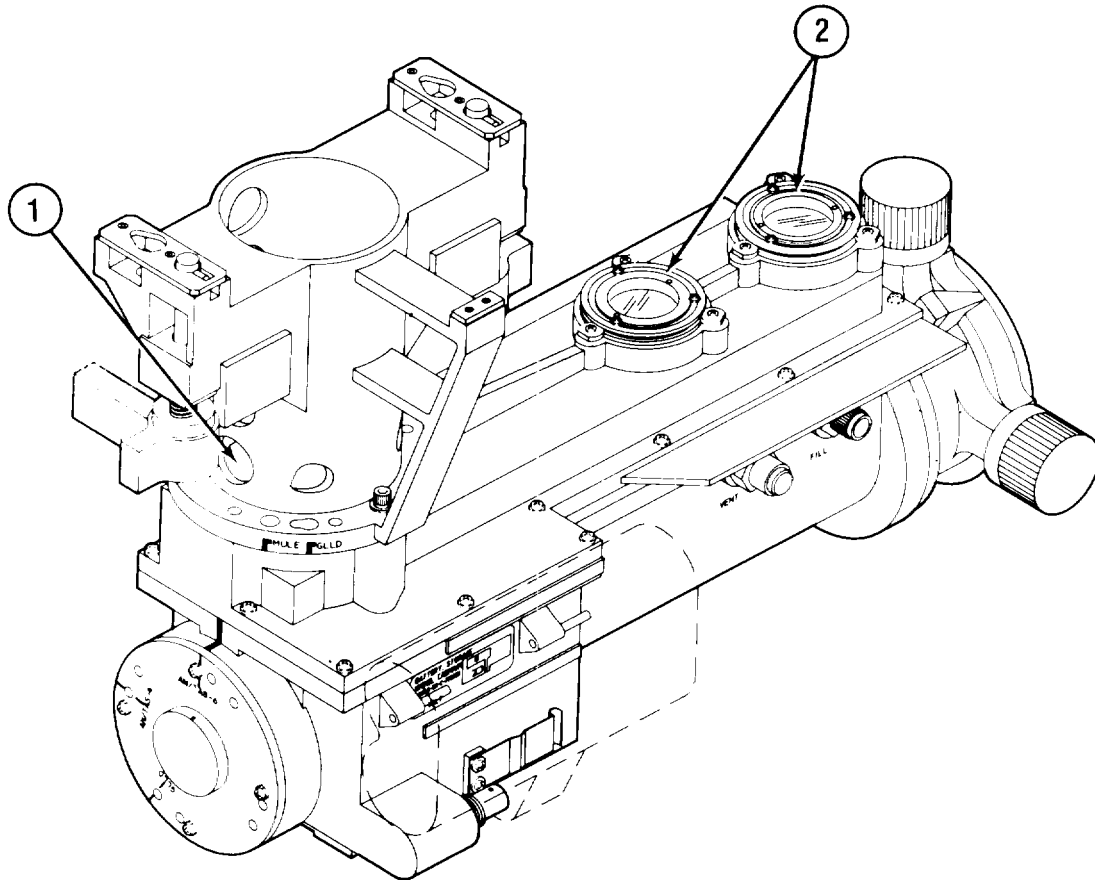

- A. To remove foreign matter from IR window (1), rinse IR window (1) with fresh water.
- B. If visible light windows (2) are dirty, refer to cleaning procedures (para 2-8).

END OF TASK

## Section V. OPERATION UNDER UNUSUAL CONDITIONS

---

SECTION CONTENTS	PARA	PAGE
SCOPE	2-24	2-58
OPERATION IN FREEZING TEMPERATURES	2-25	2-59
OPERATION IN DUSTY OR SANDY AREAS	2-26	2-62
OPERATION IN RAINY OR HUMID CONDITIONS	2-27	2-63
OPERATION IN SALT WATER AREAS	2-28	2-64

---

### 2-24. SCOPE

Section V describes procedures to be used when the operator is faced with unusual conditions.

## 2-25. OPERATING IN FREEZING TEMPERATURES (Sheet 1 of 3)

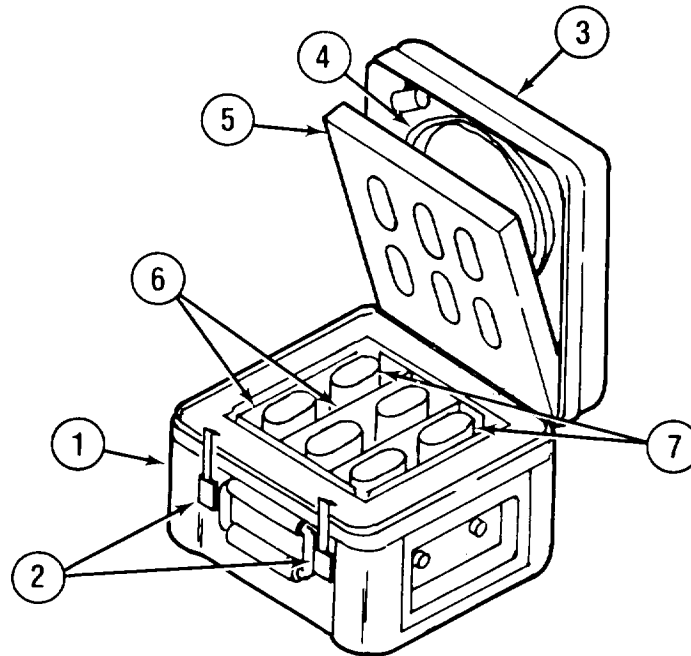

### NOTE

Night Sight battery operating time is reduced at low temperatures. The Arctic Kit (1) is provided for use under such conditions.

- A. Open Arctic Kit (1) by lifting latches (2) and cover (3).
- B. Remove power cable (4) from between insulation (5) and cover (3) of Arctic Kit (1).
- C. Remove heating pads (6) (Item 3, Appendix D) from Arctic Kit (1).
- D. Install six batteries (7) by connecting battery connectors to connectors inside Arctic Kit (1).

GO TO NEXT PAGE

**2-25. OPERATION IN FREEZING TEMPERATURES (CONT)**  
**(Sheet 2 of 3)**

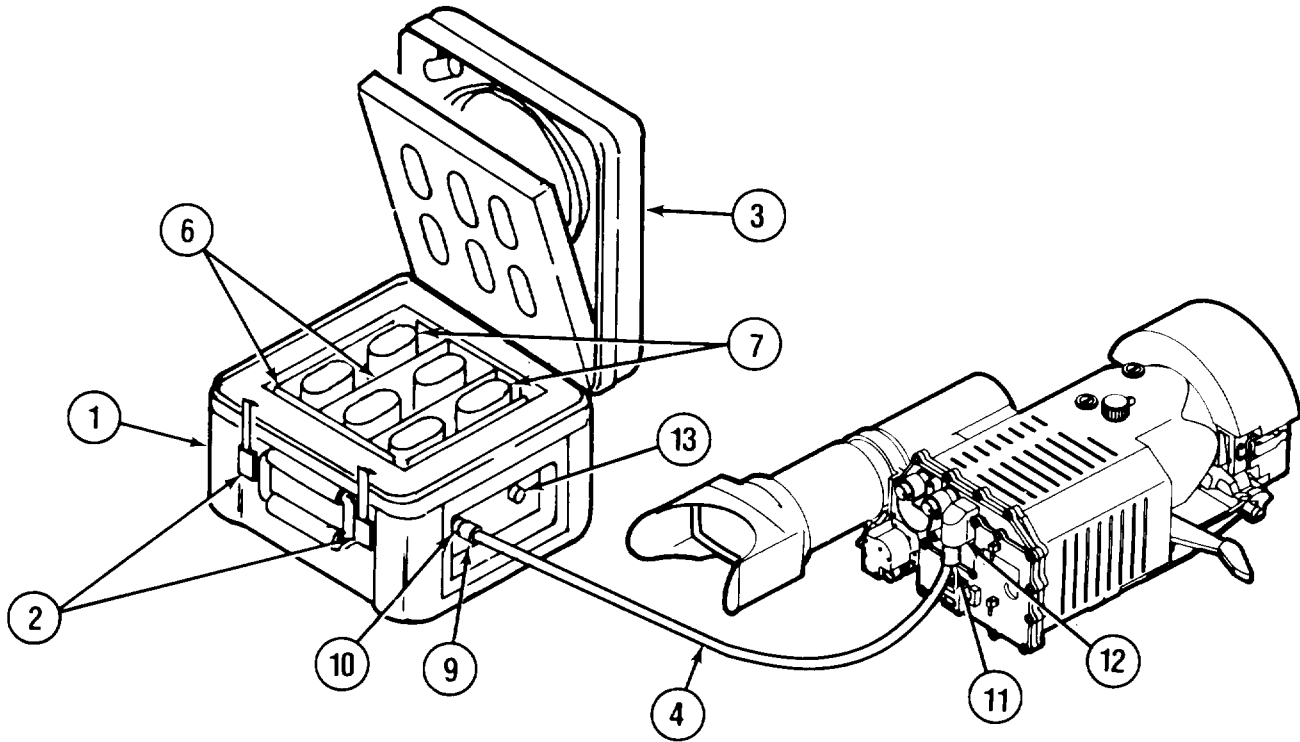

- E. Remove heating pads (6) from pad covers (8).
- F. Add water to heating pads (6) per directions printed on pad cover (8).
- G. Install heating pads (6) into pad covers (8).
- H. Pack six heating pads (6) into Arctic Kit (1) on all four sides and between batteries (7).
- I. Install cover (3) on Arctic Kit (1) and secure latches (2).
- J. Connect power cable (4) connector (9) to Arctic Kit connector J7 (10).
- K. Connect power cable (4) connector (11) to Night Sight connector J1 (12).
- L. Set switch S1 (13) to position 1 for first battery, position 2 for second battery, etc.
- M. The Arctic Kit may be shut down by setting switch S1 (13) to OFF and removing and stowing power cable (4) in cover (3).

GO TO NEXT PAGE

## 2-25. OPERATING IN FREEZING TEMPERATURES (CONT) (Sheet 3 of 3)

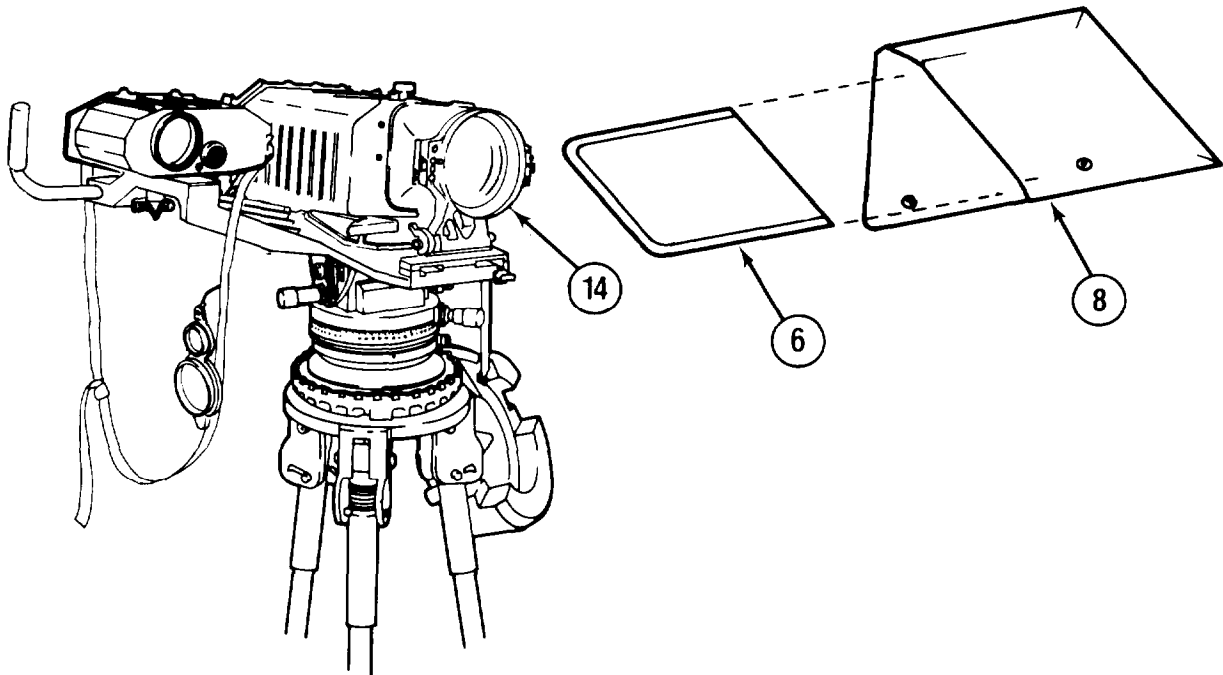

**CAUTION**

Lens surface coating is easily damaged. If operation of Night Sight is hampered by fogging, frosting, or icing over, do not attempt to remove it by wiping or rubbing. Ice crystals can scratch coating. Do not breathe on lens surface. Keep front lens covered when Night Sight is not in use.

- N. To remove fogging from lens (14), clean lens (para 2-8).
- O. To remove frost or ice from lens (14), use heating pad pack (Item 3, Appendix D) from Arctic Kit (1).
- P. Remove heating pad (6) from pad cover (8) and add water to heating pad (6) per directions printed on pad cover (8).
- Q. Hold heating pad (6) against lens surface until frost or ice is melted. Do not rub heating pad (6) on lens (14).
- R. Proceed to clean lens (14) as described in paragraph 2-8.

END OF TASK

## 2-26. OPERATION IN DUSTY OR SANDY AREAS

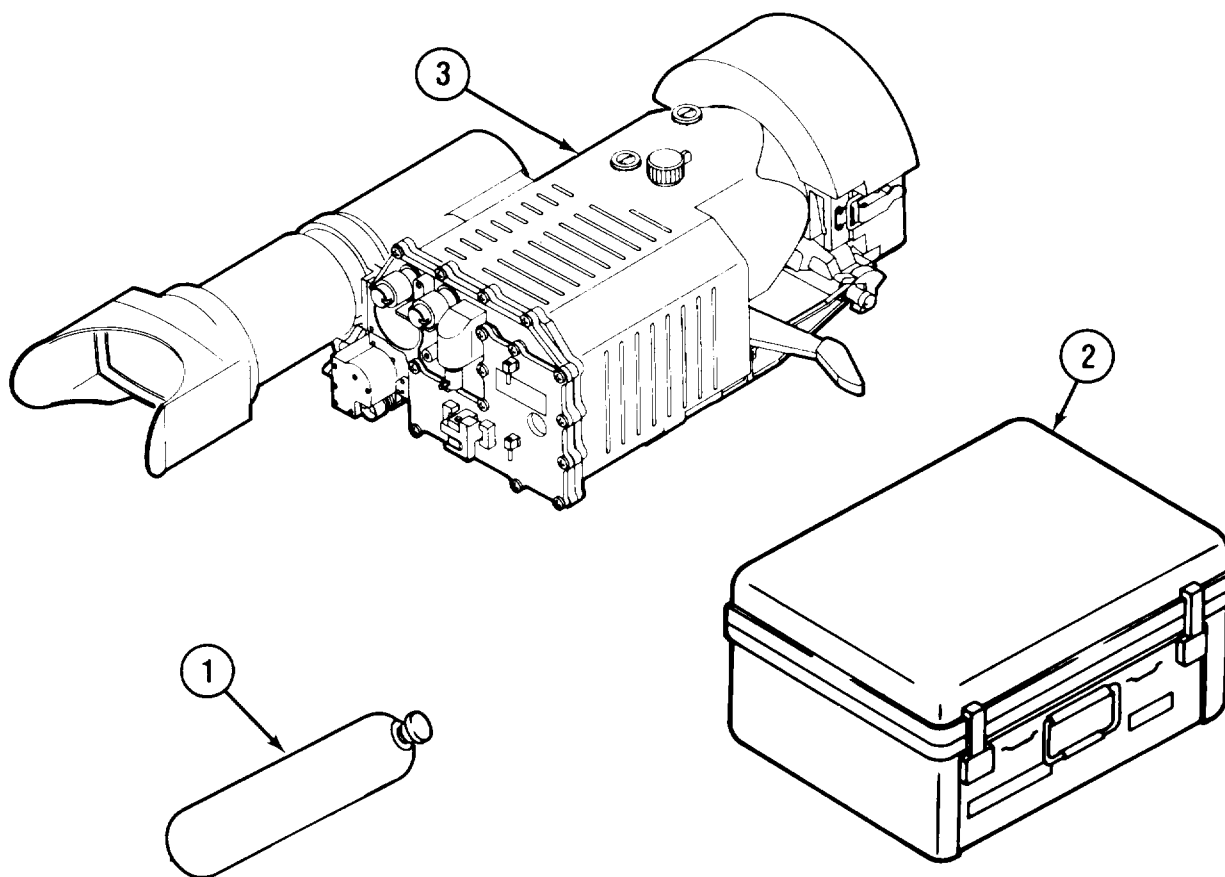

**CAUTION**

Operating in dusty or sandy areas can cause pitting and scratching of optical elements and damage to mechanical components unless the precautions given below are observed.

- A. Prior to inserting coolant cartridge (1), insure receptacle is free of dust or dirt.
- B. Keep field handling case (2) closed unless removing or replacing items.
- C. Remove all dust and sand from the Night Sight exterior (3) after operation.
- D. Do not brush or wipe dust from lens. Clean only per instructions in paragraph 2-8.

END OF TASK

## 2-27. OPERATION IN RAINY OR HUMID CONDITIONS

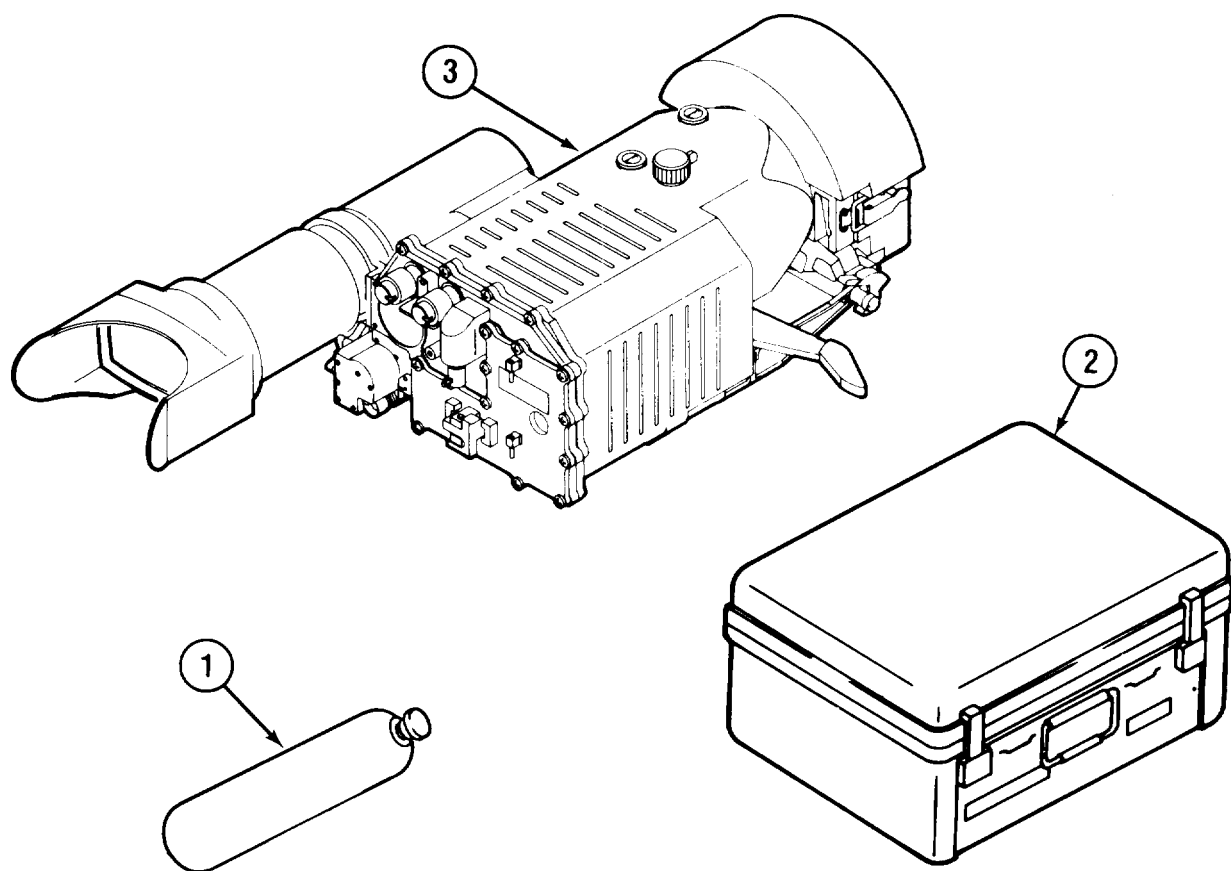

**CAUTION**

Operation in rainy or humid conditions can cause corrosion and deterioration of Night Sight unless precautions given below are observed.

- A. Prior to inserting coolant cartridge (1), insure receptacle is free of moisture.
- B. Keep field handling case (2) closed unless removing or replacing items.
- C. After exposure to rain or high humidity, dry outside of Night Sight (3) (except lens) with clean dry cloth.
- D. Clean lens per instructions in paragraph 2-8.

END OF TASK

**2-28. OPERATION IN SALT WATER AREAS**

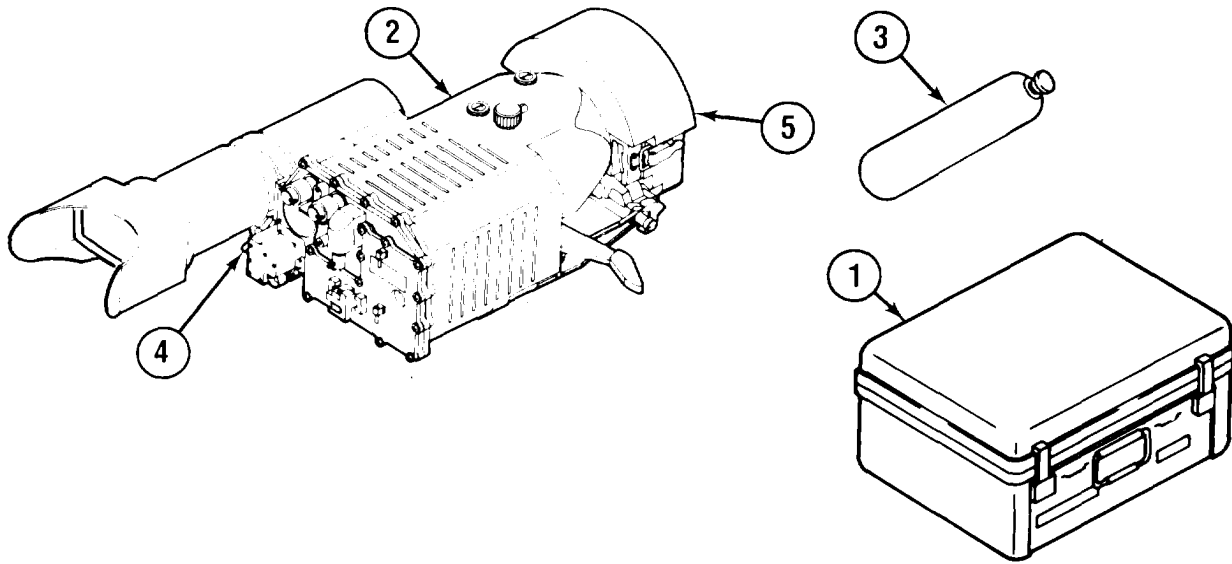

**CAUTION**

Operation in salt water areas can cause corrosion of Night Sight unless the following instructions are observed.

- A. Keep field handling case (1) closed unless removing or replacing items. After exposure to salt water, flush off Night Sight (2) with clean fresh water.

NOTE

Night Sight (2) may be immersed in water, if a charged coolant cartridge (3) is in place and the actuator (4) is in the ON position. The afocal cover (5) will normally air-dry in one hour.

- B. Flush lens with potable water to remove any remaining particles.
- C. Dry all other parts with a clean cloth. Do not disassemble.
- D. Clean lens per instructions in paragraph 2-8.
- E. Insure field handling case (1) is clean and dry prior to stowing Night Sight (2).

END OF TASK



## Section VI. COMPONENT STOWAGE AND TRANSPORTATION DATA

SECTION CONTENTS	PARA	PAGE
SCOPE	2-29	2-65
NIGHT SIGHT STOWAGE IN APC	2-30	2-66
BORESIGHT COLLIMATOR STOWAGE IN APC	2-31	2-67
AN/GVS-5 STOWAGE IN APC	2-32	2-68
CABLE 2W2 STOWAGE IN APC	2-33	2-69
TRIPOD ASSEMBLY STOWAGE IN APC	2-34	2-70
COOLANT CARTRIDGE PACK AND BATTERY PACK STOWAGE IN APC (CURBSIDE)	2-35	2-71
COOLANT CARTRIDGE PACK AND BATTERY PACK STOWAGE IN APC (ROADSIDE)	2-36	2-72
TRANSPORTATION DATA	2-37	2-73

### 2-29. SCOPE

This section provides field stowage and transportation information for the AN/UAS-11 Equipment Set and its support equipment.

## 2-30. NIGHT SIGHT STOWAGE IN APC

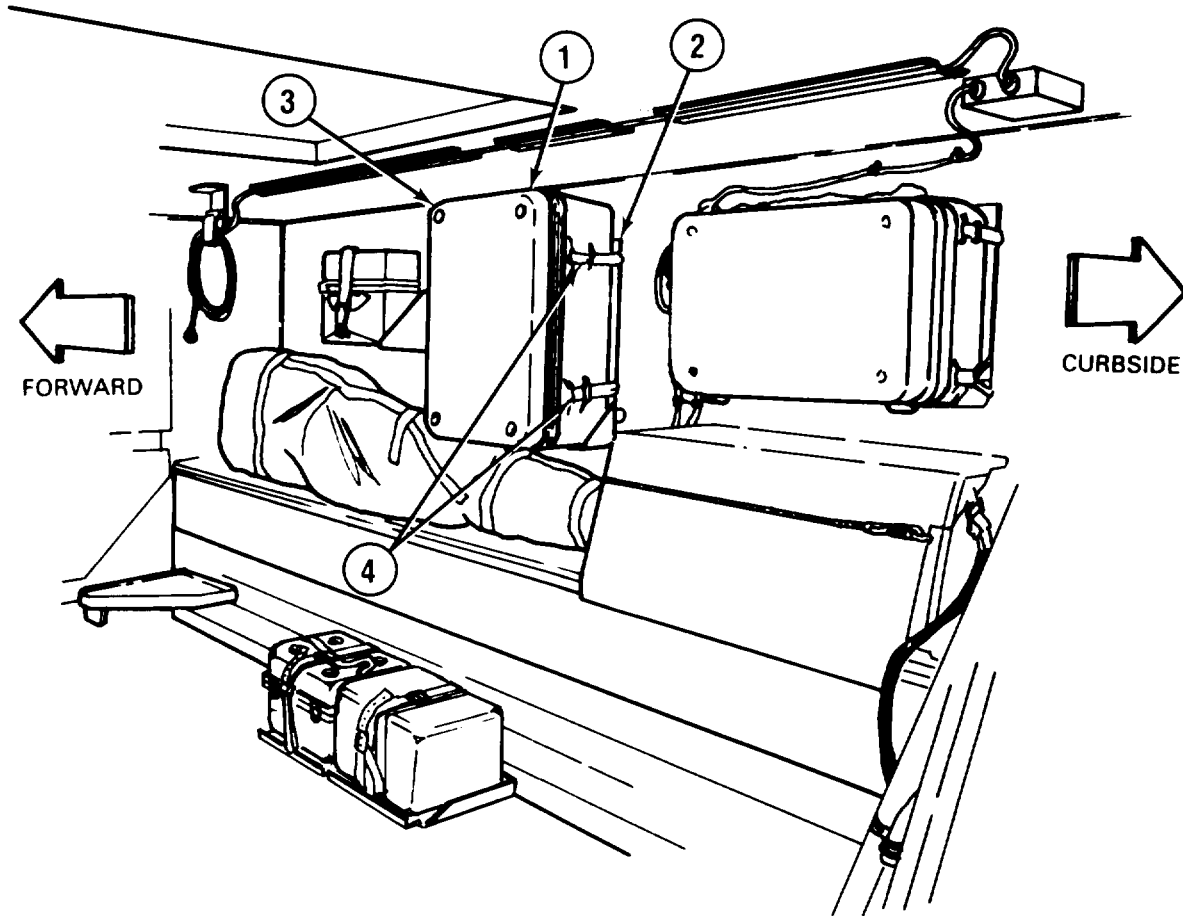

### NOTE

Night Sight equipment is mounted to curbside brackets or benches unless otherwise noted.

- A. Position AN/TAS-6 Night Sight field handling case (1) in mounting bracket (2) with cover (3) opening to right (hinged side to the right).
- B. Secure Night Sight field handling case (1) to mounting brackets (2) with two tie-down straps (4).

END OF TASK

2-31. BORESIGHT COLLIMATOR STOWAGE IN APC

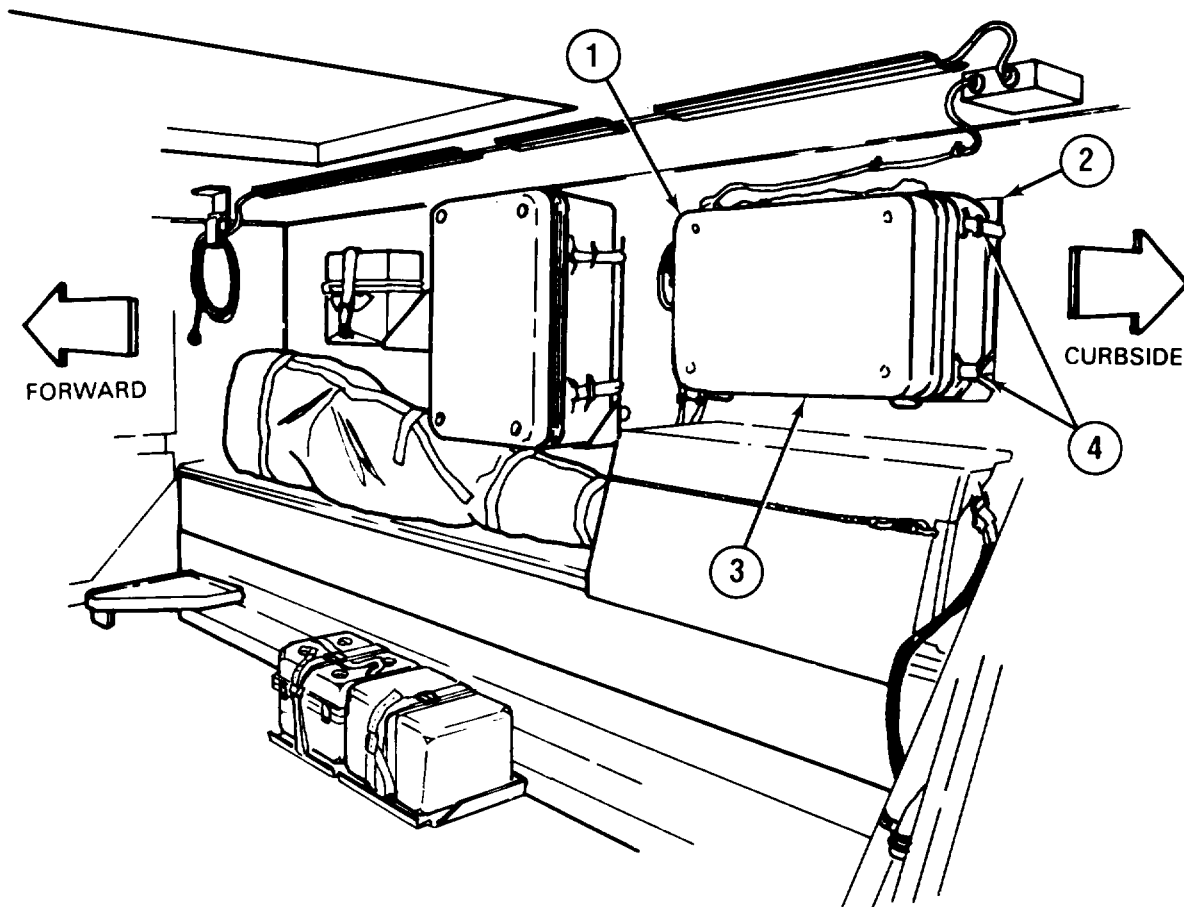

- A. Position Boresight Collimator case (1) in its mounting bracket (2) with cover (3) opening from top to bottom (hinged side on bottom).
- B. Secure Boresight Collimator case (1) to mounting bracket (2) with two tiedown straps (4).

END OF TASK

2-32. AN/GVS-5 STOWAGE IN APC

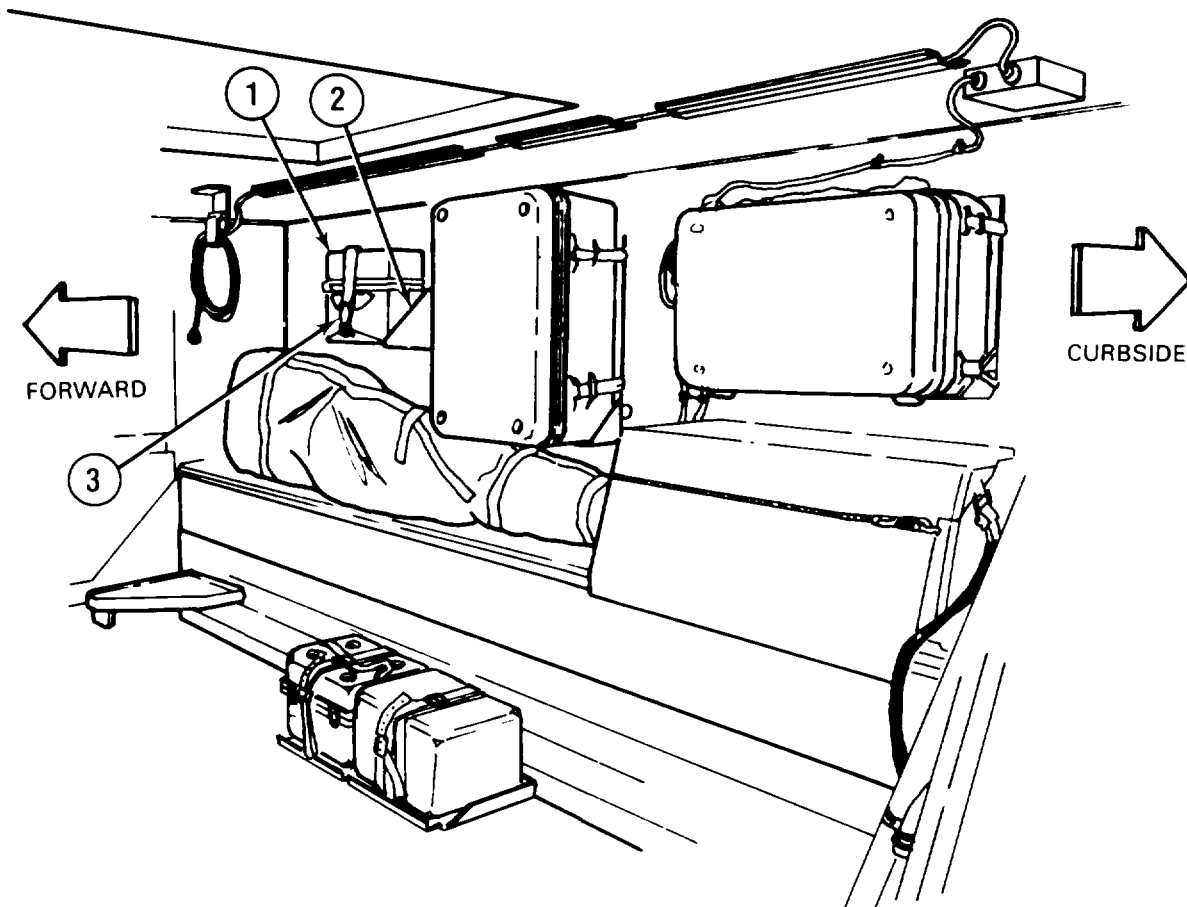

- A. Position AN/GVS-5 carrying case (1) in support bracket (2).
- B. Secure AN/GVS-5 carrying case (1) in support bracket (2) with one tiedown strap (3) vertically around center of carrying case (1).

END OF TASK

2-33. CABLE 2W2 STOWAGE IN APC

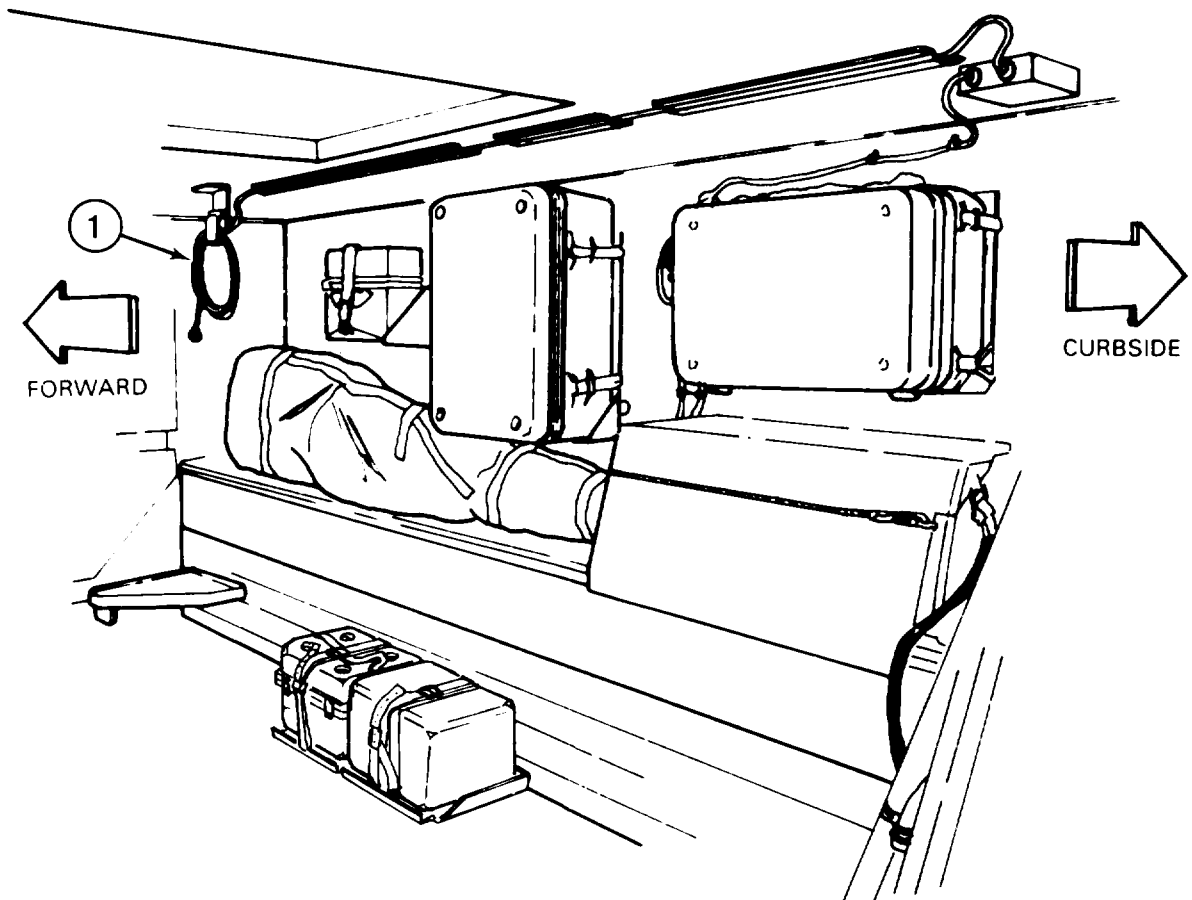

Cable 2W2 (1) is stowed as shown.

END OF TASK

2-34. TRIPOD ASSEMBLY STOWAGE IN APC

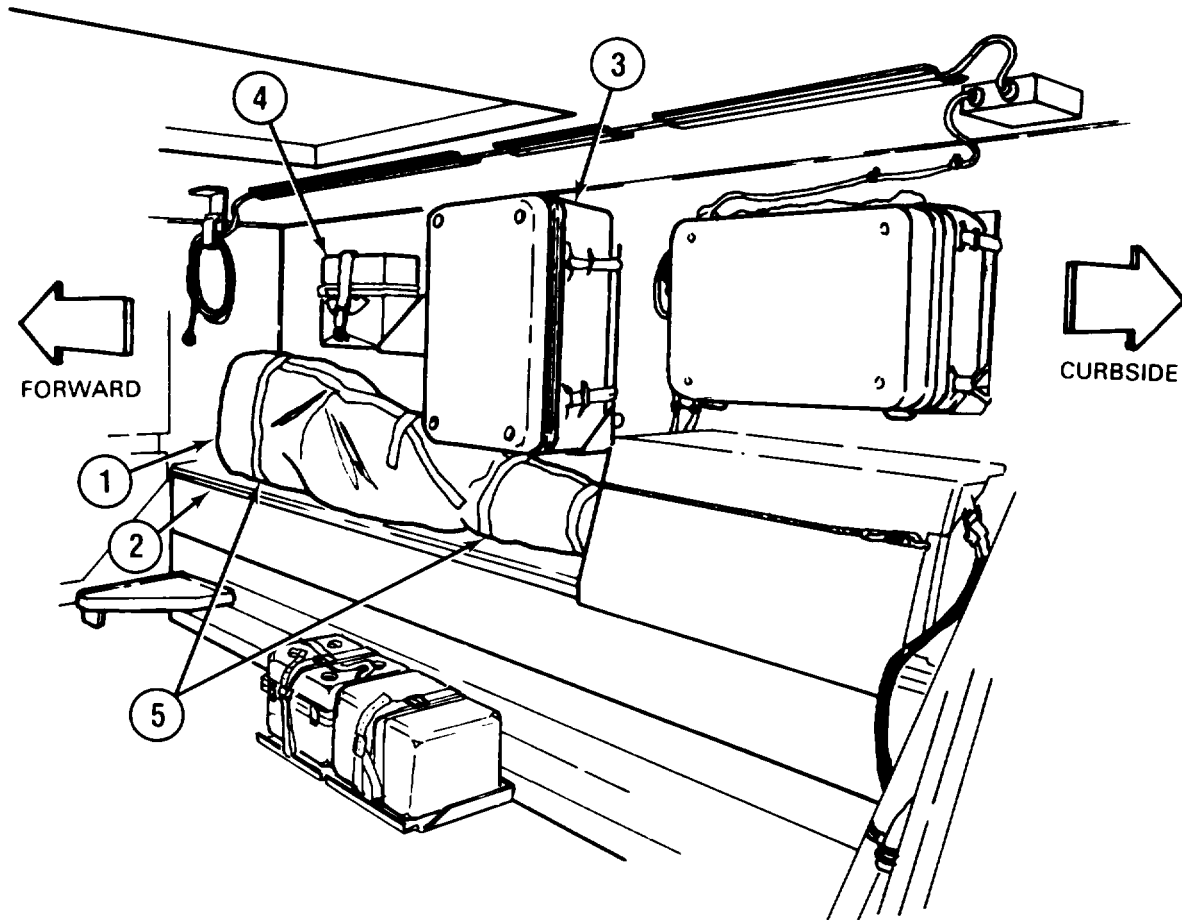

- A. Position Tripod carrying bag (1) on track housing (2) beneath Night Sight field handling case (3) and AN/GVS-5 carrying case (4).
- B. Secure Tripod carrying bag (1) with two tiedown straps (5).

END OF TASK

## 2-35. COOLANT CARTRIDGE PACK AND BATTERY PACK STORAGE IN APC (CURBSIDE)

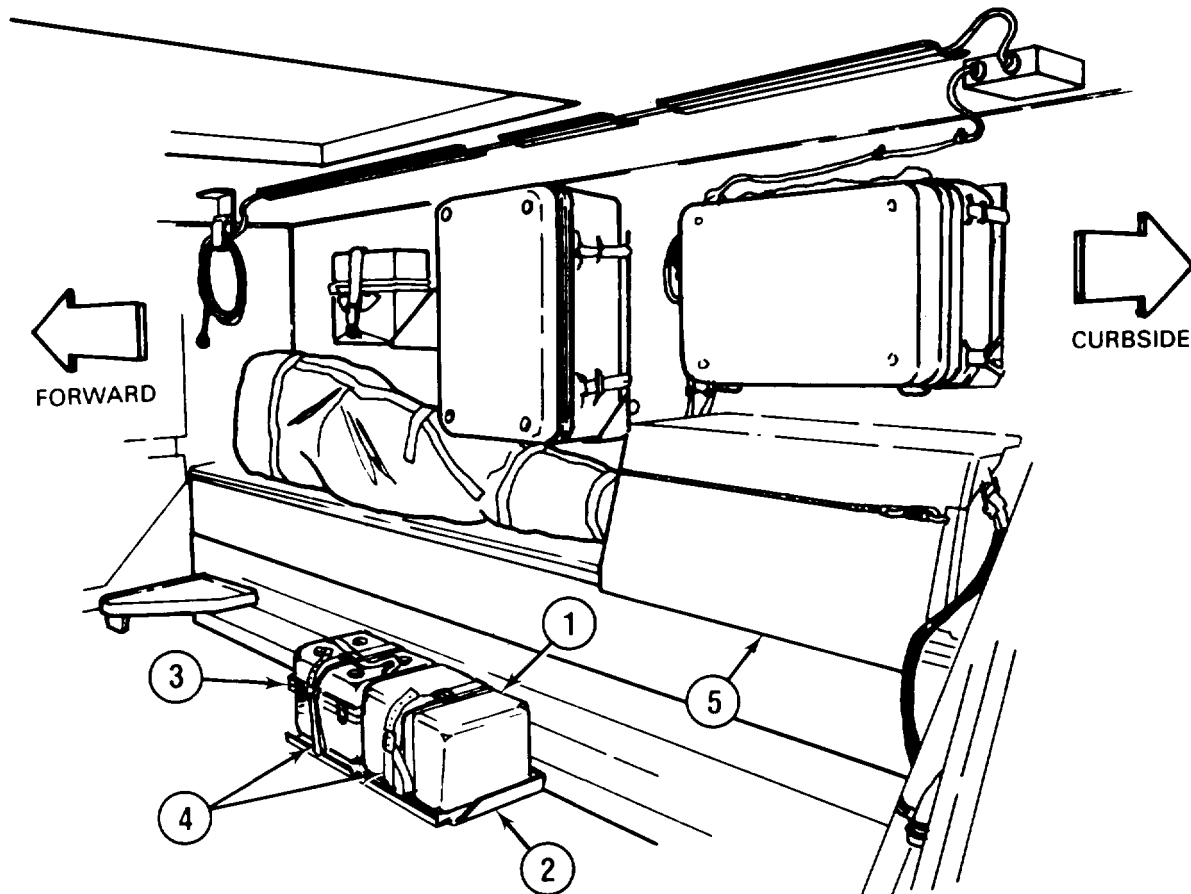

- A. Position coolant cartridge pack (1), horizontally and latch-side down, on curbside mounting bracket (2).
- B. Position battery pack (3) in upright position on curbside mounting bracket (2).
- C. Secure coolant cartridge pack (1) and battery pack (3) with tiedown straps (4).
- D. Lower troop seat (5), if provided, to insure clearance above coolant cartridge pack (1).

END OF TASK

**2-36. COOLANT CARTRIDGE PACKS AND BATTERY PACK STOWAGE IN APC (ROADSIDE)**

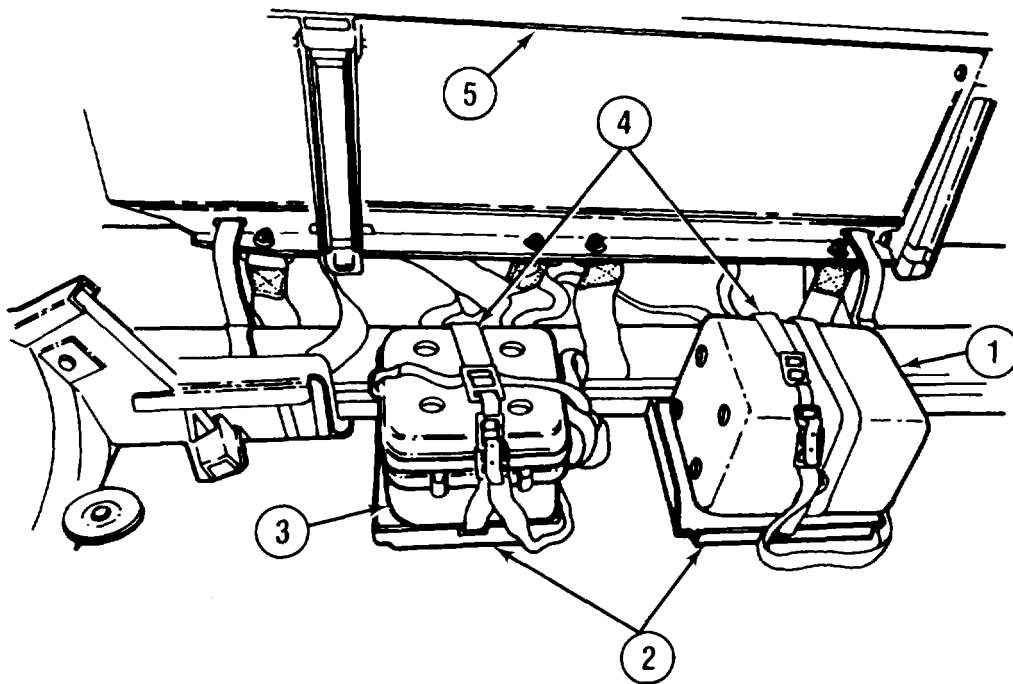

- A. Position coolant cartridge pack (1), horizontally and latch-side down, on roadside mounting bracket (2).
- B. Position battery pack (3) in upright position on roadside mounting bracket (2).
- C. Secure coolant cartridge pack (1) and battery pack (3) with tiedown straps (4).
- D. Lower troop seat (5) if provided, to insure clearance above coolant cartridge pack (1).

END OF TASK



**2-37. TRANSPORTATION DATA  
(Sheet 1 of 2)**

Table 2-2. TRANSPORTATION DATA

	Length in (cm)	Width in (cm)	Height in (cm)	Volume cu ft (M3)	Weight lb (kg)
Night Sight	21.450 (54.483)	12.440 (31.597)	7.50 (19.05)	1.1600 (0.0328)	22.50 (10.23)
Night Sight Field Handling Case	16.20 (41.15)	22.750 (57.785)	10.250 (26.035)	2.190 (0.062)	17.00 (7.73)
Battery	1.4800 (3.7592)	3.6600 (9.2964)	5.00 (12.70)	0.0200 (0.0004)	1.70 (0.77)
Coolant Cartridge	2.1250 (5.3975)	2.1250 (5.3975)	7.78 (19.76)	0.0200 (0.0004)	1.32 (0.60)
Tripod	7.940 (20.168)	7.940 (20.168)	37.18 (94.44)	1.360 (0.038)	19.00 (8.64)
Interface Mount	18.51 (47.02)	22.69 (57.63)	9.100 (23.114)	2.2100 (0.0626)	11.0 (5.0)
Boresight Collimator	15.620 (39.674)	10.37 (26.34)	6.70 (17.02)	0.6300 (0.0177)	8.00 (3.64)
Vehicle Power Conditioner	6.20 (15.75)	7.96 (20.22)	3.13 (7.95)	0.0900 (0.0025)	7.50 (3.41)
Arctic Kit	13.00 (33.02)	13.00 (33.02)	8.75 (22.33)	0.860 (0.024)	12.00 (5.45)
Battery Case	9.65 (24.51)	9.27 (23.55)	7.08 (17.98)	0.3700 (0.0102)	5.00 (Empty) (2.27)
Coolant Cartridge Case	9.35 (23.75)	9.20 (23.37)	10.71 (27.20)	0.5300 (0.0151)	7.00 (Empty) (3.18)

**2-37. TRANSPORTATION DATA  
(Sheet 2 of 2)**

Table 2-2. TRANSPORTATION DATA (CONT)

	Length in (cm)	Width in (cm)	Height in (cm)	Volume cu ft (M3)	Weight lb (kg)
Tripod Case	12.70 (32.26)	41.25 (104.78)	11.25 (28.58)	9.4100 (0.0966)	21.00 (9.55)
Bore sight Collimator Case	15.12 (38.40)	21.00 (53.34)	9.38 (23.83)	1.7200 (0.0488)	16.00 (Empty) (7.27)

**CHAPTER 3**  
**NIGHT SIGHT MAINTENANCE INSTRUCTIONS**

---

**CHAPTER OVERVIEW**

This chapter contains operator maintenance instructions for the Night Sight. Information pertaining to troubleshooting the Night Sight is in Section I. Section II contains removal and replacement procedures. In order to perform the 180-day verification for the Night Sight, do the Night Sight Troubleshooting Procedures (para 3-2).

<u>CHAPTER CONTENTS</u>	<u>PAGE</u>
Section I. NIGHT SIGHT TROUBLESHOOTING PROCEDURES	3-1
Section II. MAINTENANCE PROCEDURES	3-8

**Section I. NIGHT SIGHT TROUBLESHOOTING PROCEDURES**

<u>SECTION CONTENTS</u>	PARA	PAGE
SCOPE	3-1	3-1
NIGHT SIGHT TROUBLESHOOTING PROCEDURES	3-2	3-2

**3-1. SCOPE**

This section contains troubleshooting procedures for the Night Sight.

### 3-2. NIGHT SIGHT TROUBLESHOOTING PROCEDURES (Sheet 1 of 6)

#### NOTE

- Prior to starting troubleshooting, insure the Night Sight has freshly charged battery and fully charged coolant cartridge installed.
- Follow steps in order given in the procedures. Do not skip any steps.  
When you enter the "NO" chain, perform the procedure and/or repairs as instructed in the corrective action block.
- ž Unless otherwise specified, after performing the corrective action of the "NO" chain always return to the "START" of the procedure you were checking. When more than one corrective action may be required, perform the first corrective action, return to "START", and repeat the procedure. **If** the problem still exists, perform the next corrective action and repeat.
- The eyeshield assembly may be removed during troubleshooting to aid in observing raster. A socket-head screw key is stored in the Night Sight field handling case for this purpose.
- If corrective action contained in this manual does not remedy the malfunction, turn AN/UAS-11 Equipment Set in through normal channels of supply.

GO TO NEXT PAGE

**3-2. NIGHT SIGHT TROUBLESHOOTING PROCEDURES (CONT)**  
 (Sheet 2 of 6)

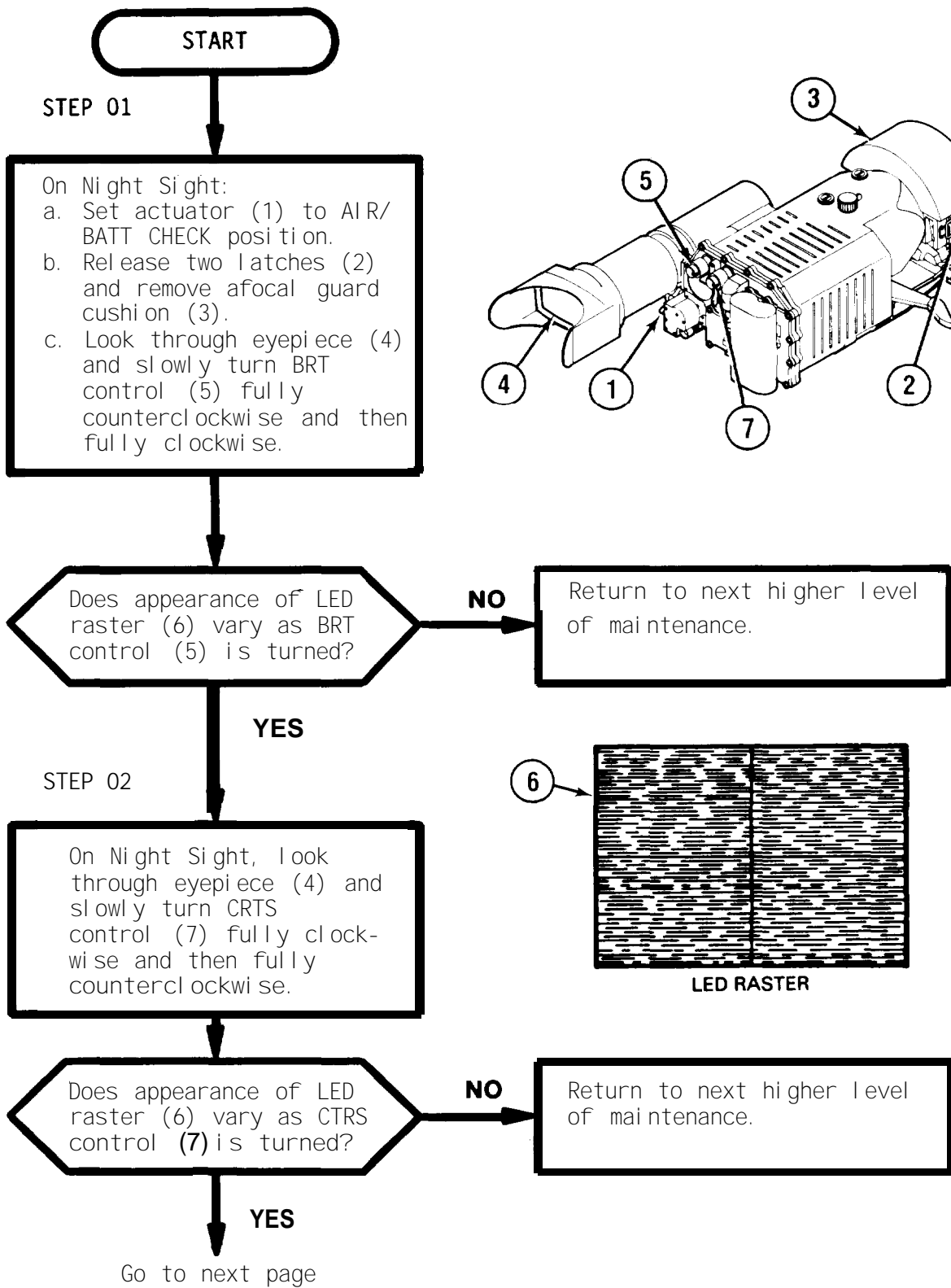

3-2. NIGHT SIGHT TROUBLESHOOTING PROCEDURES (CONT)  
(Sheet 3 of 6)

Continued from previous page

STEP 03

On Night Sight, look through eyepiece (4).

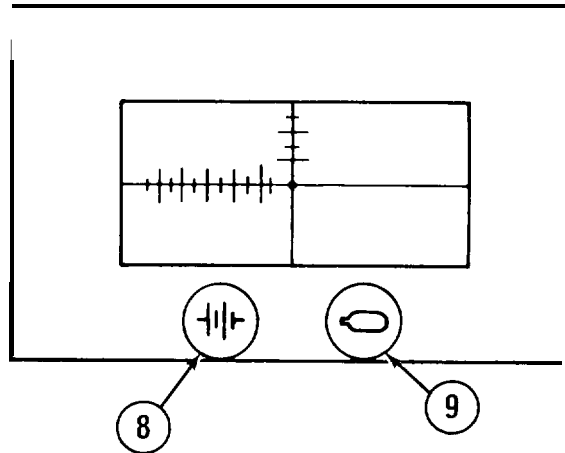

Is LED raster (6) free of obstruction from shutters?

NO

Return to next higher level of maintenance.

YES

Is battery monitor (8) extinguished?

NO

a. Remove and replace battery (para 3-4). Illuminated monitor indicates low battery.  
b. Return to next higher level of maintenance.

YES

Is coolant cartridge monitor (9) extinguished?

NO

a. Remove and replace coolant cartridge (para 3-6). Illuminated monitor indicates low pressure.  
b. Return to next higher level of maintenance.

YES

STEP 04

On Night Sight, set actuator (1) to ON.

Go to next page

3-2. NIGHT SIGHT TROUBLESHOOTING PROCEDURES (CONT)  
(Sheet 4 of 6)

Continued from previous page

**NOTE**  
Allow 15 seconds for Night Sight cooldown before proceeding. Allow more time for a less than fully charged coolant cartridge.

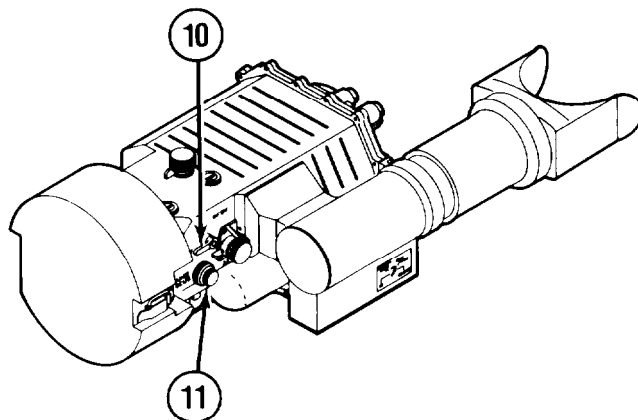

STEP 05

**On Night Sight:**  
a. Set field-of-view handle (10) to NFOV.  
b. Adjust RANGE FOCUS control (11) to obtain best focus of displayed image.

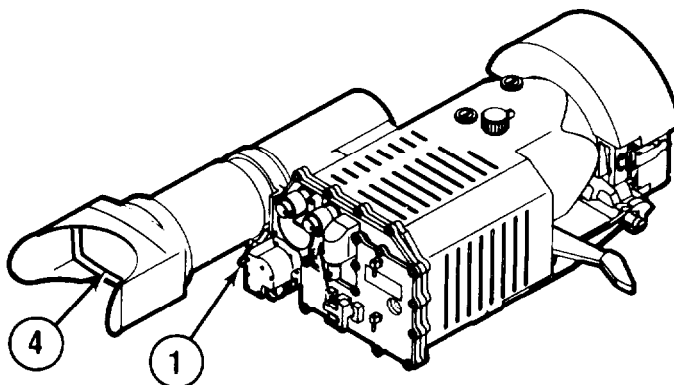

Is displayed image sharp and clear?

NO

Return to next higher level of maintenance.

YES

STEP 06

**On Night Sight, look through eyepiece (4) and set field-of-view handle (10) to WFOV.**

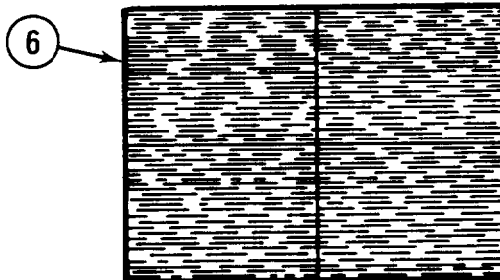

LED RASTER

Go to next page

3-2. NIGHT SIGHT TROUBLESHOOTING PROCEDURES (CONT)  
(Sheet 5 of 6)

Continued from previous page

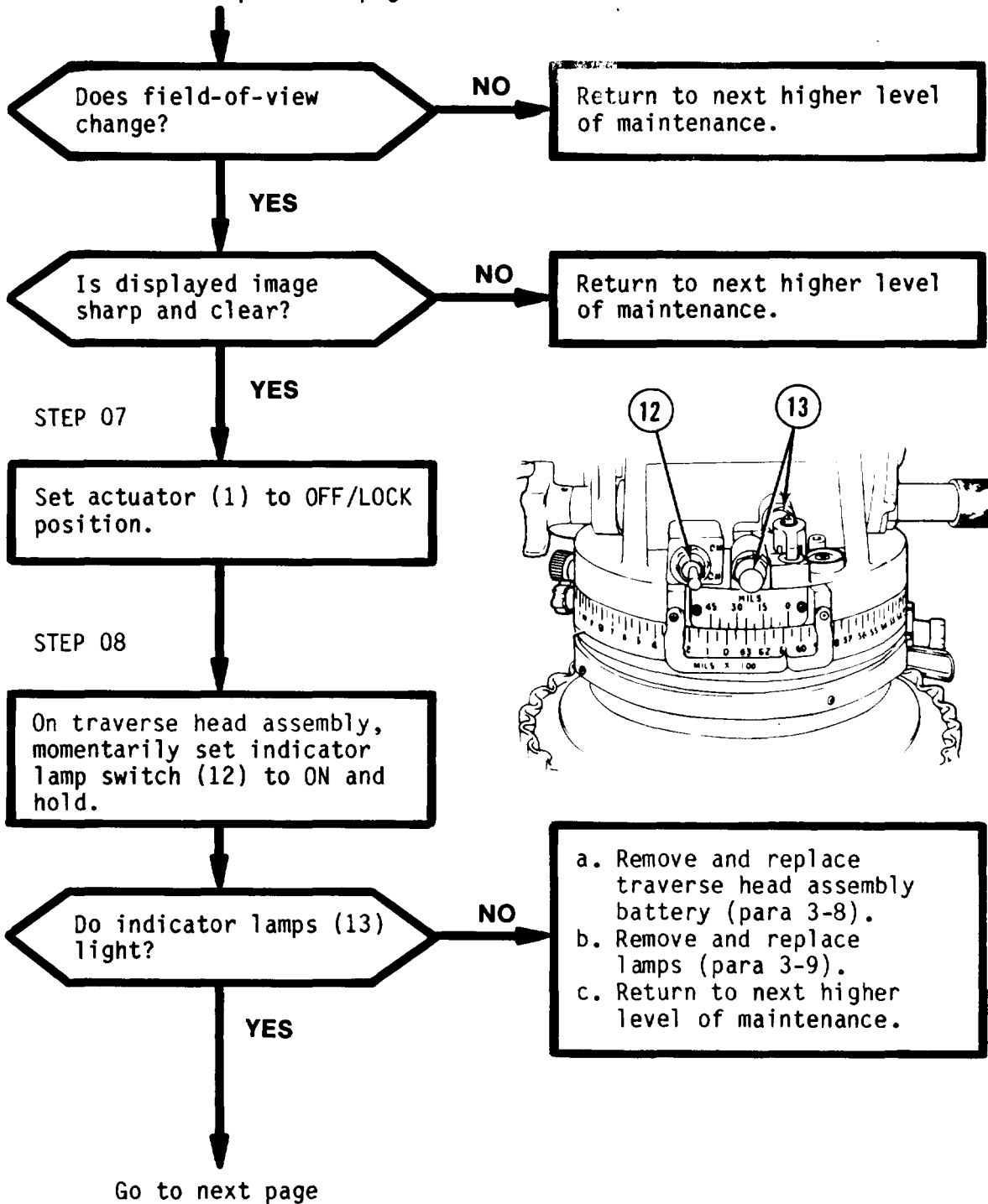



3-2. NIGHT SIGHT TROUBLESHOOTING PROCEDURES (CONT)  
(Sheet 6 of 6)

Continued from previous page

STEP 09

Release indicator lamp switch (12).

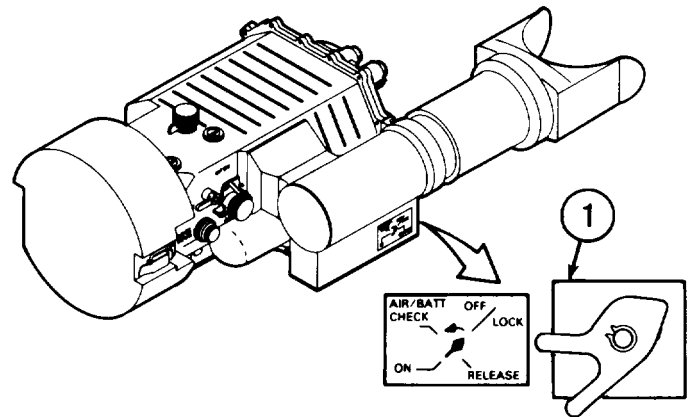

On Boresight Collimator (14) look down Mount Assembly (15) to IR window (16).

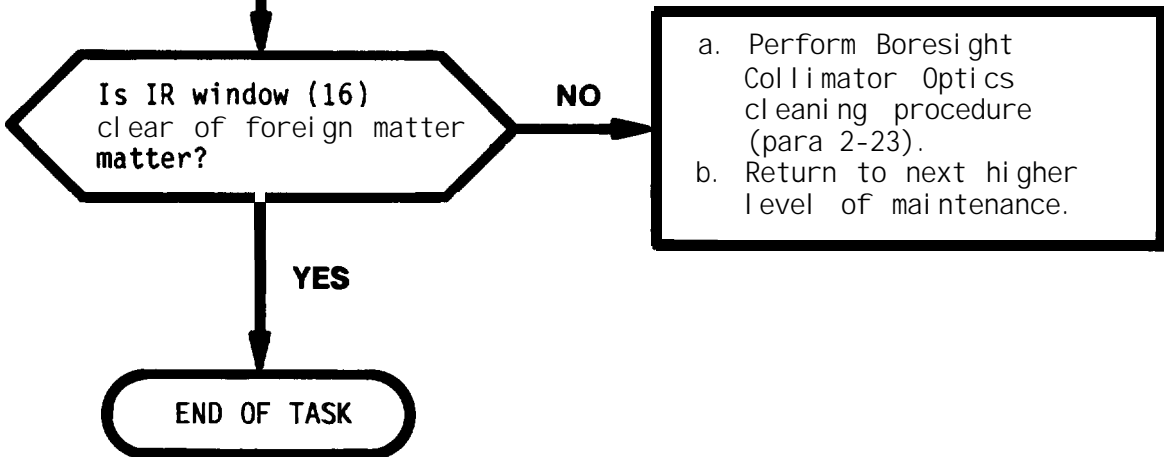
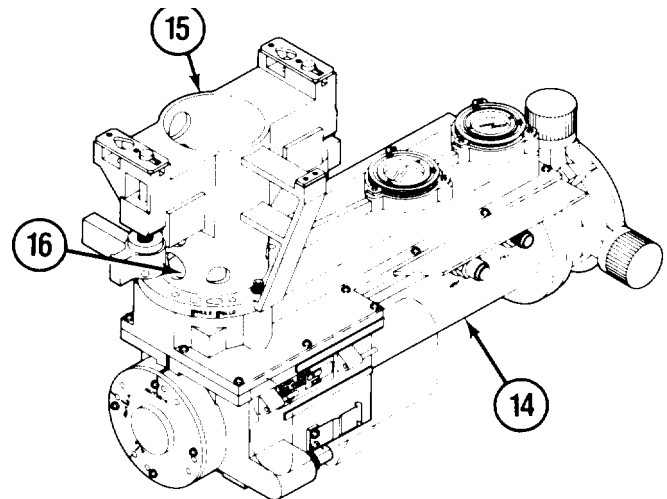

**Section II. MAINTENANCE PROCEDURES**

<u>SECTION CONTENTS</u>	PARA	PAGE
SCOPE	3-3	3-8
REMOVAL AND REPLACEMENT OF OF NIGHT SIGHT BATTERY	3-4	3-9
REMOVAL AND REPLACEMENT OF BORESIGHT COLLIMATOR BATTERY	3-5	3-10
REMOVAL AND REPLACEMENT OF OF COOLANT CARTRIDGE	3-6	3-11
REMOVAL AND REPLACEMENT OF EYESHIELD	3-7	3-12
REMOVAL AND REPLACEMENT OF TRAVERSE HEAD ASSEMBLY BATTERY	3-8	3-13
REMOVAL AND REPLACEMENT OF AZIMUTH SCALE LAMP AND LEVEL INDICATOR LAMP	3-9	3-14
TOUCHUP PAINTING	3-10	3-15

**3-3. SCOPE**

This section contains removal and replacement procedures for the Night Sight and traverse head assembly.

### 3-4. REMOVAL AND REPLACEMENT OF NIGHT SIGHT BATTERY

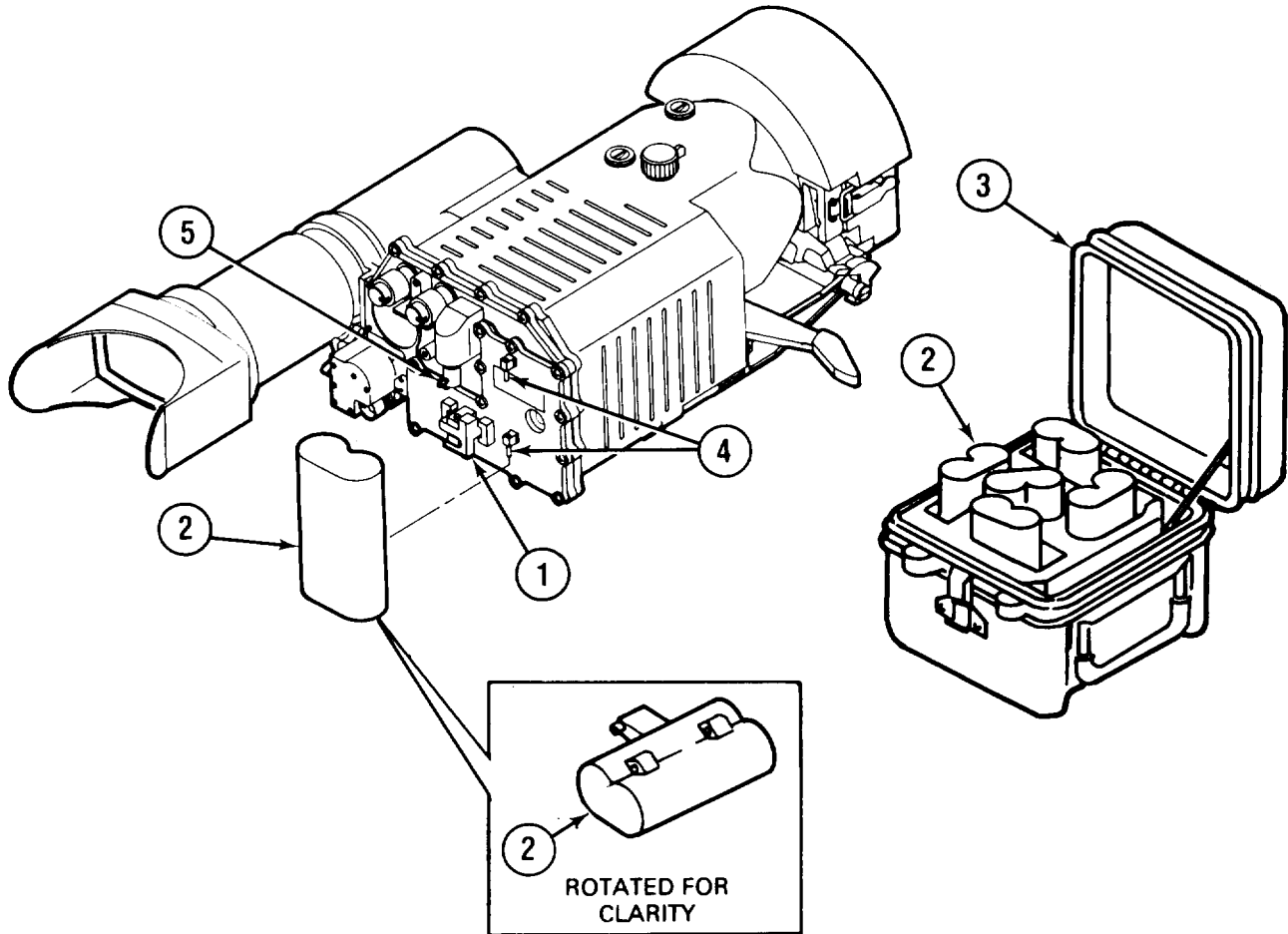

#### STEP 1

#### REMOVAL

- A. Pull battery retainer (1) out to unlocked position and move battery (2) downward to remove.
- B. Place discharged battery (2) in battery case (3) inverted to indicate it has been used and is to be recharged later.

#### STEP 2

#### REPLACEMENT

- A. Align and move charged battery (2) upward onto guide pins (4).
- B. Engage connector (5) and move battery retainer (1) to locked position.

END OF TASK

### 3-5. REMOVAL AND REPLACEMENT OF BORESIGHT COLLIMATOR BATTERY

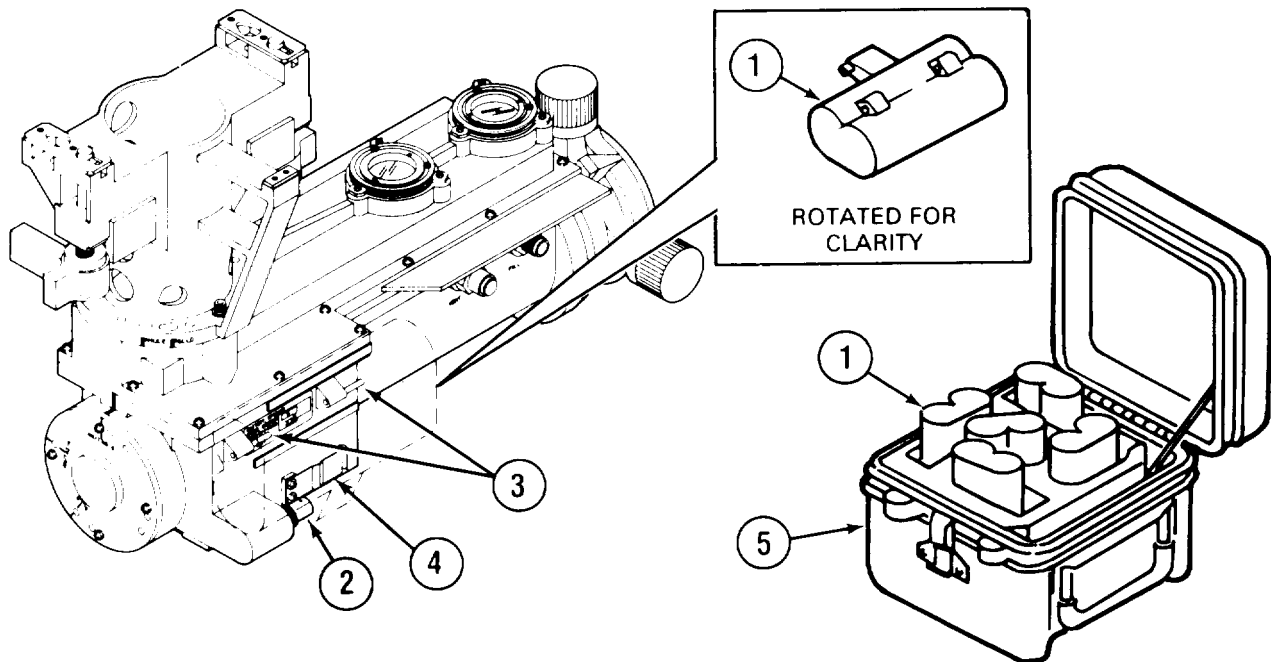

NOTE

The Boresight Collimator battery and Night Sight battery are interchangeable.

STEP 1

REMOVAL

- A. Move battery (1) to the right to disengage battery connector (2) and slide battery (1) from guide pins (3).
- B. Ensure battery clip (4) remains in place.
- C. Place discharged battery (1) in battery case (5) inverted to indicate it has been used and is to be recharged later.

STEP 2

REPLACEMENT

- A. Remove charged battery (1) from battery case (5).
- B. Align battery (1) with guide pins (3).
- C. Push battery (1) onto guide pins (3), engaging battery connector (2).
- D. Ensure battery clip (4) engages battery (1).

END OF TASK

### 3-6. REMOVAL AND REPLACEMENT OF COOLANT CARTRIDGE

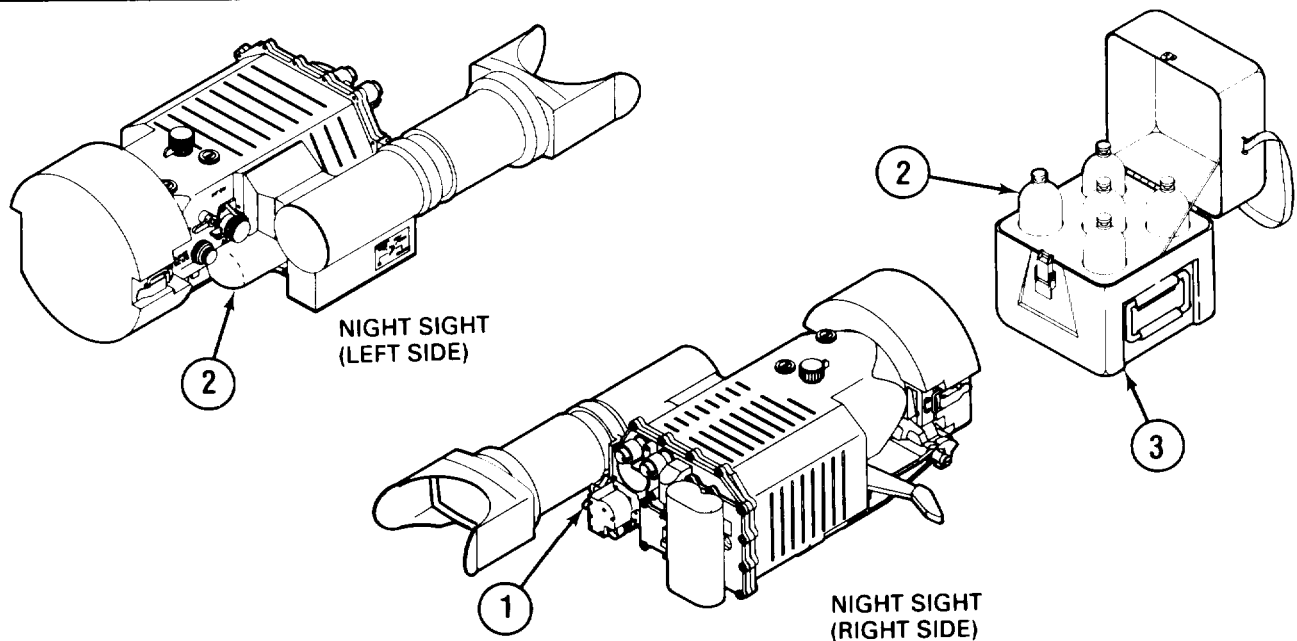

#### STEP 1

#### REMOVAL

- A. Set actuator (1) to RELEASE position.
- B. Remove discharged coolant cartridge (2).
- C. Place coolant cartridge (2) in coolant cartridge case (3).

#### STEP 2

#### REPLACEMENT

#### NOTE

Actuator (1) must be in RELEASE position before the coolant cartridge (2) can be installed.

- A. Remove charged coolant cartridge (2) from coolant cartridge case (3).
- B. Insert charged coolant cartridge (2) through cartridge retainer clip (hidden from view) and into the actuator assembly (1).
- C. Set actuator (1) to OFF/LOCK position to secure coolant cartridge (2) in place.

END OF TASK

### 3-7. REMOVAL AND REPLACEMENT OF EYESHIELD

**TOOLS:**

0.050-inch socket head screw key

**EQUIPMENT CONDITION:**

Assembled

**MATERIALS:**

None

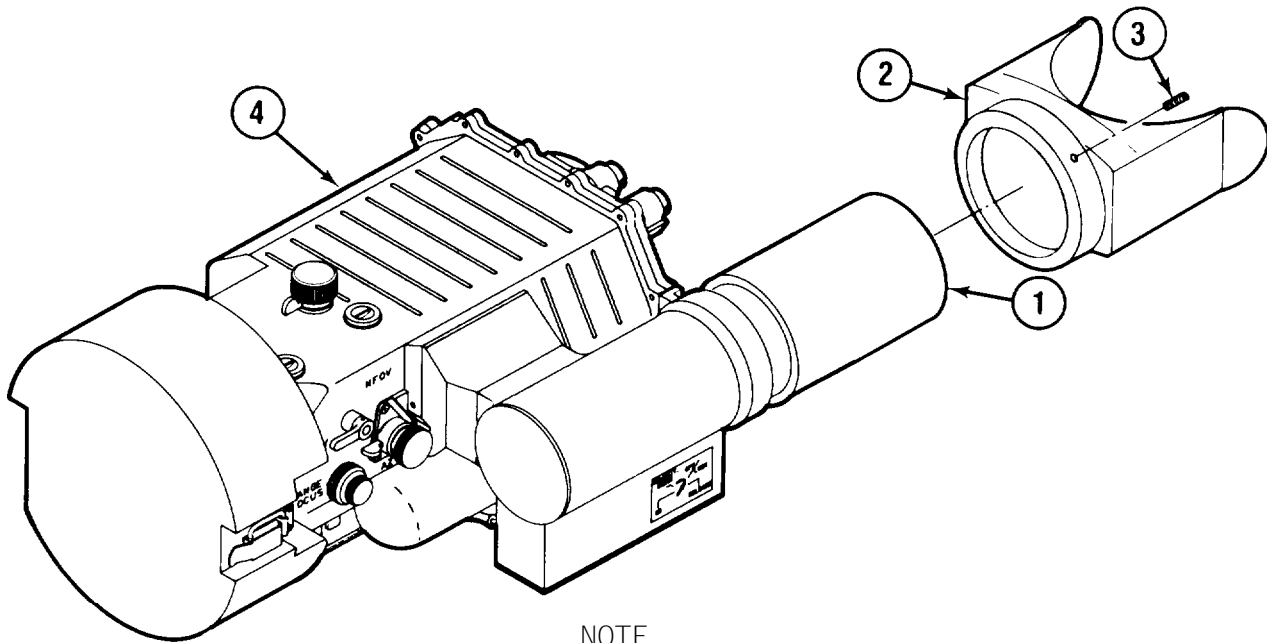

NOTE

Cleaning Night Sight Lens (1) is more easily accomplished if eyeshield assembly (2) is removed.

STEP 1

REMOVAL

- A. Remove three socket-head screws (3) from eyeshield assembly (2).
- B. While supporting eyeshield assembly (2), lift eyeshield assembly (2) from Night Sight (4).

STEP 2

REPLACEMENT

- A. Position eyeshield assembly (2) on Night Sight (4).
- B. While supporting eyeshield assembly (2), install three socket-head screws (3).

END OF TASK

### 3-8. REMOVAL AND REPLACEMENT OF TRAVERSE HEAD ASSEMBLY BATTERY

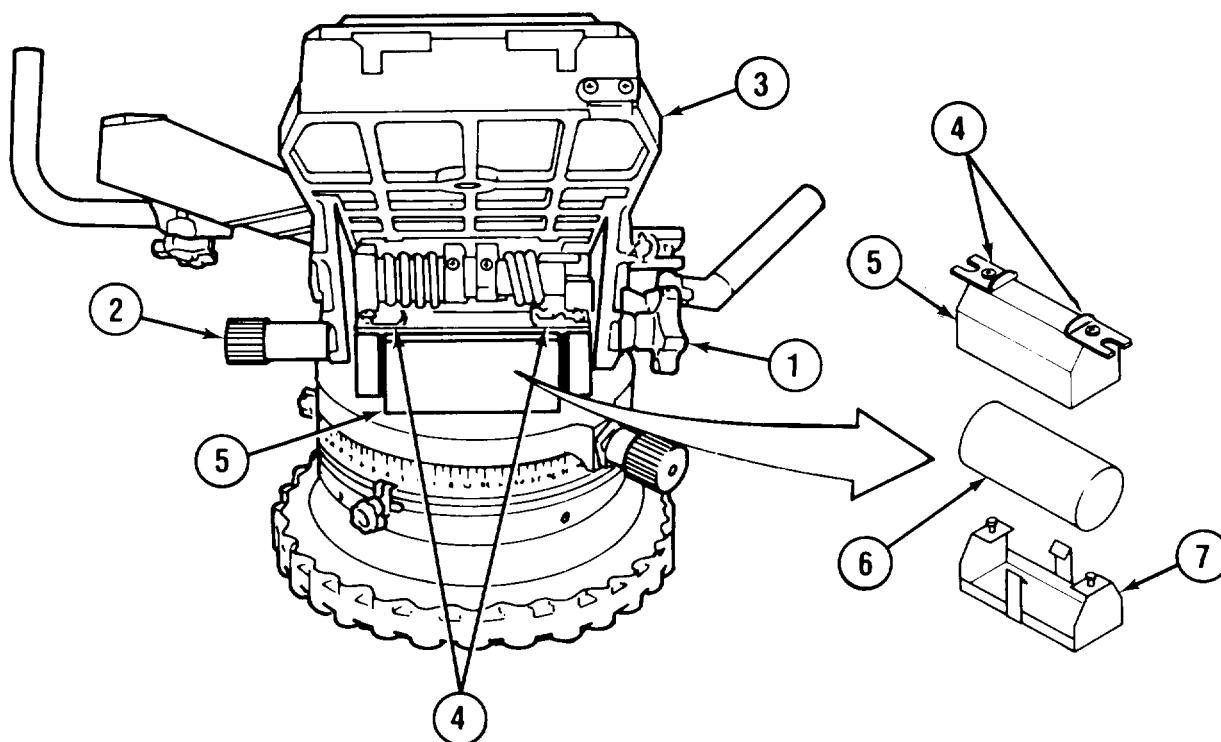

#### STEP 1 REMOVAL

- A. Loosen elevation brake knob (1).
- B. Pull elevation stow knob (2).
- C. Tilt traverse head assembly (3) upward and tighten elevation brake knob (1).
- D. Release battery latches (4) and remove battery cover (5).
- E. Remove discharged battery (6) (Item 1, Appendix D) from battery clip (7).

#### STEP 2 REPLACEMENT

- A. Install charged battery (6) and battery cover (5).
- B. Slide battery latches (4) to closed position.
- C. While supporting traverse head assembly (3), loosen elevation brake knob (1).
- D. Lower traverse head assembly (3) to horizontal position.

END OF TASK

### 3-9. REMOVAL AND REPLACEMENT OF AZIMUTH SCALE LAMP AND LEVEL INDICATOR LAMP

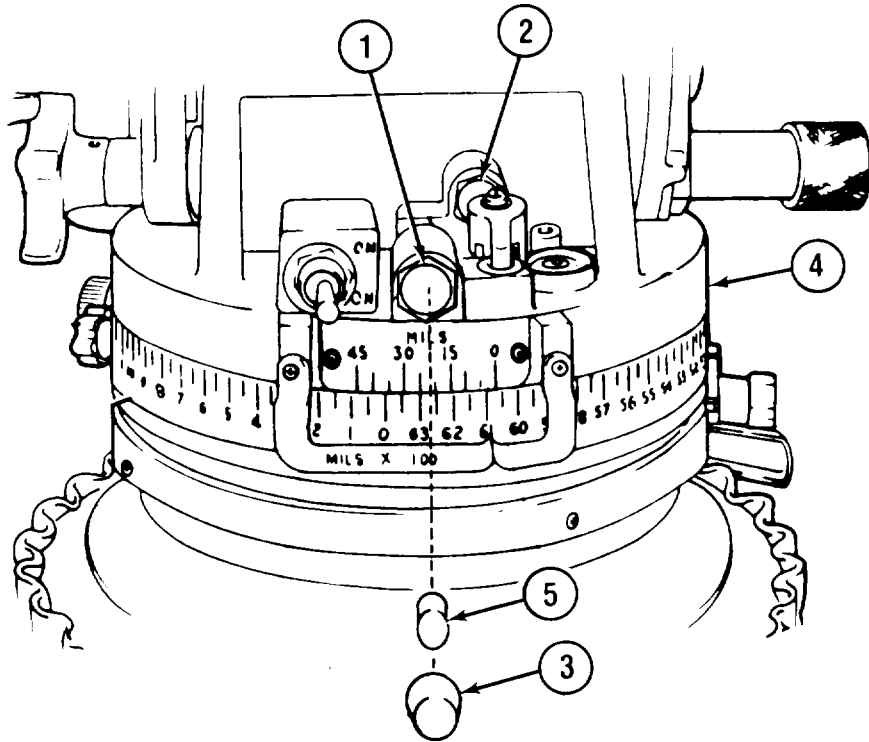

#### NOTE

Azimuth scale lamp (1) and level indicator lamp (2) are removed in the same way. Only the azimuth scale lamp (1) is covered in this procedure.

#### STEP 1

#### REMOVAL

- A. Unscrew azimuth scale lamp cover (3) and remove from traverse head assembly (4).
- B. Remove incandescent lamp (5).

#### STEP 2

#### REPLACEMENT

- A. Install incandescent lamp (5).
- B. Install azimuth scale lamp cover (3) on traverse head assembly (4).

END OF TASK



### 3-10. TOUCHUP PAINTING

#### MATERIALS:

CARC paint (Item 5, Appendix D)  
Primer (Item 6, Appendix D)



Chemical agent resistant coating (CARC) is extremely toxic and flammable. Never use where sparks, smoking or open flame may be present. CARC, if improperly used, may cause long term health problems. Avoid contact with skin, breathing of fumes, or ingestion of dried particles. Use must be monitored by the local safety office and preventive medicine support activity. Refer to TM 43-0139 for applicable safety precautions prior to removal or application of CARC.



Use masking tape to ensure that no paint is applied to bolt holes, attaching surfaces, preformed packings, preformed packing grooves, or surfaces treated with lubricant.

#### TOUCHUP PAINTING INSTRUCTIONS

Operator personnel are authorized to spot paint the external surfaces of night sight with CARC paint (Item 5, Appendix D). Prime (Item 6, Appendix D) metal surfaces in accordance with MIL-C-46168. Refer to TM 43-0139 for spot painting instructions.

END OF TASK

## APPENDIX A

### REFERENCES

---

#### A-1. SCOPE

This appendix lists all forms, technical manuals, and miscellaneous publications referenced in this manual.

#### A-2. FORMS

Recommended Changes to Publications and Blank Forms . . . . . DA Form 2028  
 Equipment Inspection and Maintenance Work Sheet . . . . . DA Form 2404

#### A-3. TECHNICAL MANUALS

Procedures for Destruction of Electronics Materiel to  
 Prevent Enemy Use (Electronics Command) . . . . . TM 750-244-2

Operator's Manual, Laser Infrared Observation Set AN/GVS-5 . . . TM 11-5860-201-10

Organizational, Direct Support, and General Support for  
 Collimator, Boresight SU-93/TAS and  
 Collimator, Boresight SU-93A/TAS . . . . . TM 9-5855-885-24

Repair Parts and Special Tools List,  
 Night Vision Sight Set, Infrared AN/UAS-11 . . . . . TM 9-5855-247-24P-2

Painting Instructions for Field Use . . . . . TM 43-0139

#### A-4. MISCELLANEOUS PUBLICATIONS

Ionizing Radiation Protection (Licensing, Control,  
 Transportation, Disposal, and Radiation Safety) . . . . . AR 385-11

Index of Technical Publications: Technical Manuals,  
 Technical Bulletins, Supply Manuals (Types 7, 8, and  
 9), Supply Bulletins and Lubrication Orders . . . . . DA PAM 310-4

US Army Index of Modification Work Orders . . . . . DA PAM310-7

The Army Maintenance Management System (TAMMS) . . . . . DA PAM 738-750

## APPENDIX B

### COMPONENTS OF END ITEM AND BASIC ISSUE ITEMS LISTS

---

#### Section I. INTRODUCTION

##### **B-1. SCOPE**

This appendix lists components of end item and basic issue items for the AN/UAS-11 to help you inventory items required for safe and efficient operation.

##### **B-2. GENERAL**

The Components of End **Item** and Basic Issue Items Lists are divided into the following sections:

a. Section II. Components of End Item. This listing is for informational purposes only, and is not authority to requisition replacements. These items are part of the end item, but are removed and separately packaged for transportation or shipment. As part of the end item, these items must be with the end item whenever it is issued or transferred between property accounts. Illustrations are furnished to assist you in identifying the items.

b. Section III. Basic Issue Items. Not applicable

##### **B-3. EXPLANATION OF COLUMNS**

The following provides an explanation of columns found in the tabular listings:

a. Column (1) - Illustration Number (Illus Number). This column indicates the number of the illustration in which the item is shown.

b. Column (2) - National Stock Number. Indicates the National stock number assigned to the item and will be used for requisitioning purposes.

c. Column (3) - Description. Indicates the Federal item name and the FSCM in parentheses followed by the part number.

d. Column (4) - Unit of Measure (U/M). Indicates the measure used in performing the actual maintenance function. This measure is expressed by a two-character alphabetical abbreviation (e.g., ea, in, pr). If the unit of measure differs from the unit of issue, requisition the lowest unit of issue that will satisfy your requirements.

e. Column (5) - Quantity required (Qty rqr). Indicates the quantity of the item authorized to be used with/on the equipment.

**Section II. COMPONENTS OF END ITEM LIST  
INTEGRAL COMPONENTS NIGHT VISION SIGHT SET, INFRARED AN/UAS-11**

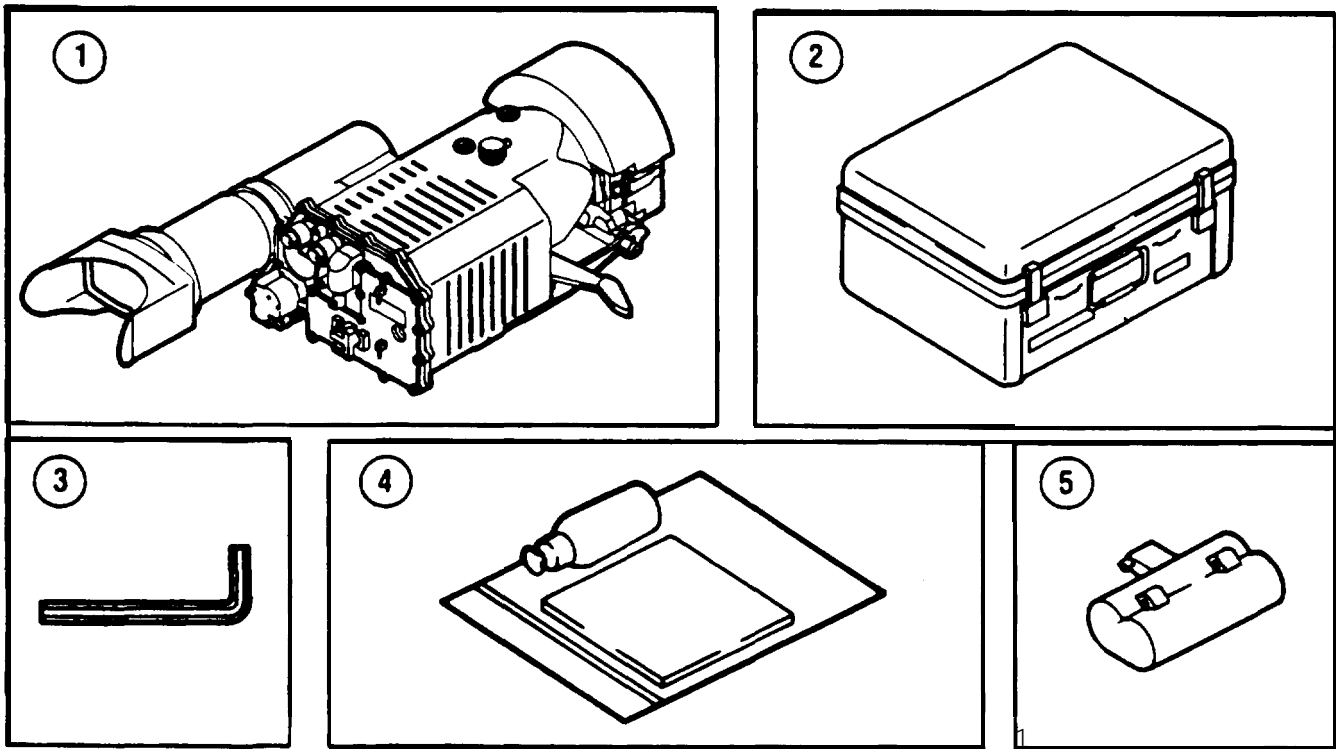

MS015524

(1) ILLUS NUMBER	(2) NATIONAL STOCK NUMBER	(3) DESCRIPTION FSCM AND PART NUMBER	(4) U/M	(5) QTY RQR
1	5855-01-037-7340	Night Vision Sight, IR, AN/TAS-6 (80063) SM-C-771739	EA	1
2	5855-01-067-7747	Field Handling Case, AN/TAS-6 (80063) SM-D-806642-1 (80063) SM-D-806811	EA	1
3	5120-00-198-5401	Key, Socket Head Type Class II 0.050 inch (94033) P37B30-2	EA	1
4	5855-01-143-4488	Lens Cleaning Kit (80063) SM-C-804452	EA	1
5	6140-01-056-5321	Battery Assembly (80063) SM-C-772052	EA	1

**INTEGRAL COMPONENTS NIGHT VISION SIGHT SET, INFRARED AN/UAS-11 CONT)**

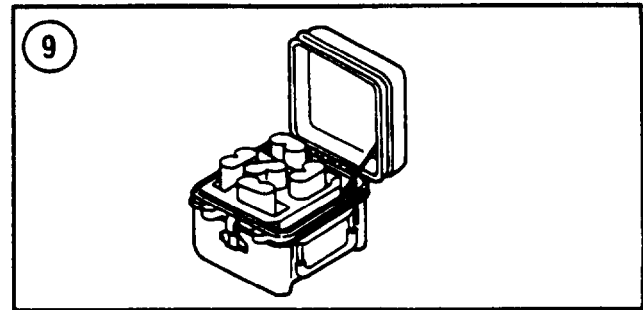
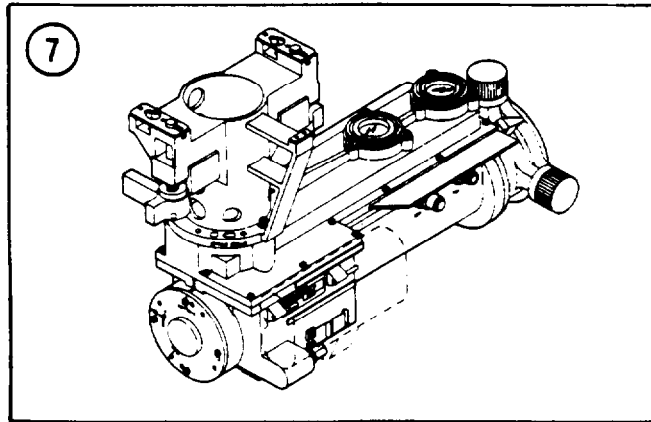
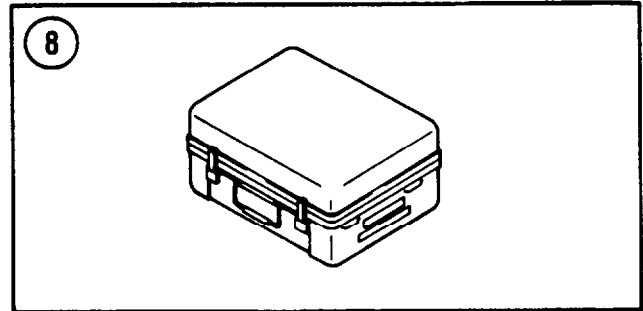
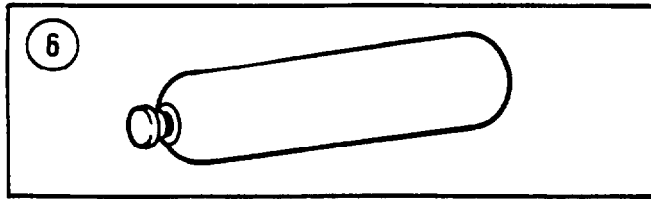

MS015525

(1) ILLUS NUMBER	(2) NATIONAL STOCK NUMBER	(3) DESCRIPTION FSCM AND PART NUMBER	(4) U/M	(5) QTY RQR
6	8120-01-070-3959	Cartridge Assembly (Coolant) (80063) SM-C-804790	EA	1
7	5855-01-109-6433	Boresight Collimator SU-93A/TAS (80063) SM-C-775002	EA	1
	5855-01-029-8730	Boresight Collimator SU-93/TAS (80063) SM-C-775087-1	EA	1
8	5850-01-227-5482	Case, Collimator (80063) SM-D-806491-1 (80063) SM-D-807945	EA	1
9	6140-01-049-5342	Battery Pack, Night Vision Sight (80063) SM-C-804438	EA	3

**INTEGRAL COMPONENTS NIGHT VISION SIGHT SET, INFRARED AN/UAS-11 (CONT)**

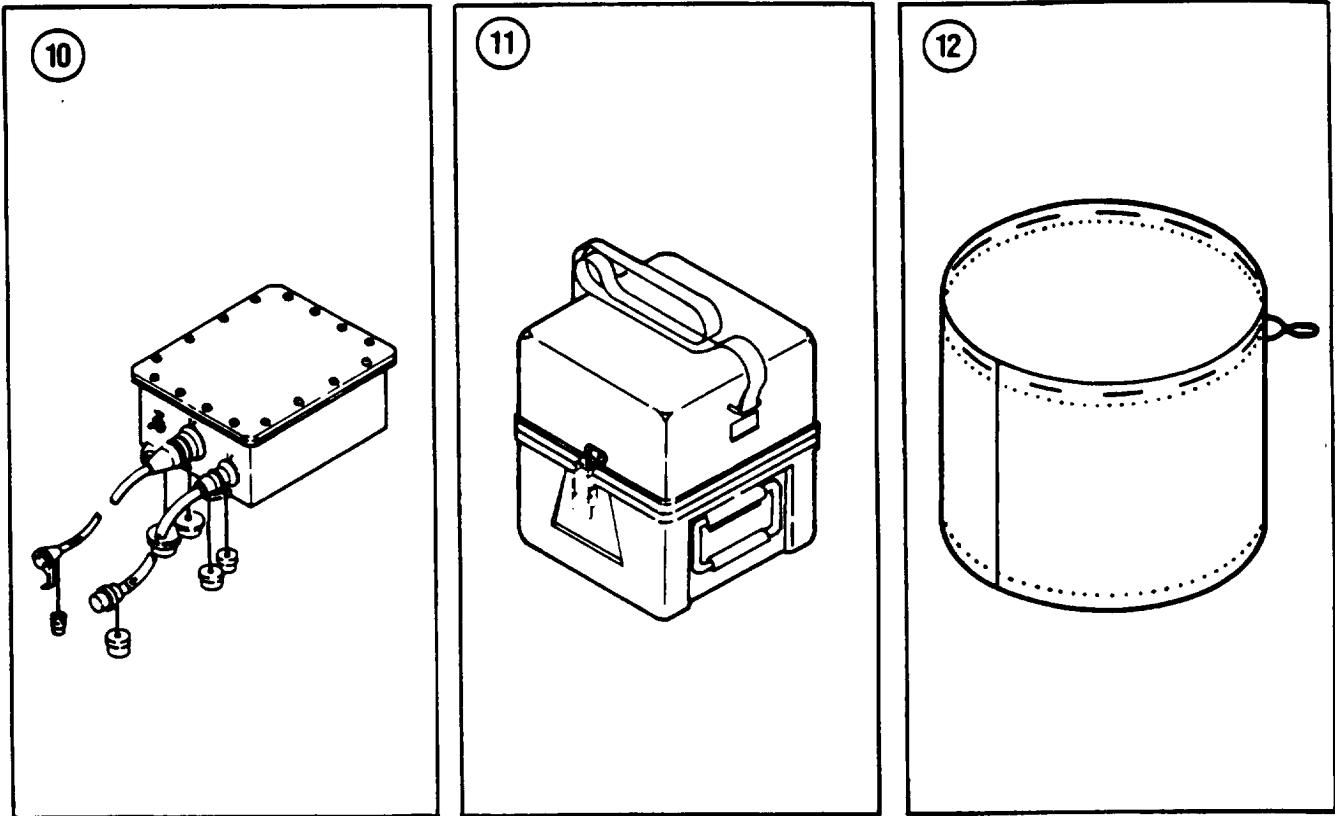

MS015526

(1) ILLUS NUMBER	(2) NATIONAL STOCK NUMBER	(3) DESCRIPTION FSCM AND PART NUMBER	(4) U/M	(5) QTY RQR
10	5855-01-049-5354	Vehicle Power Conditioner (80063) SM-D-772049-1	EA	1
11	5855-01-047-2136	Coolant Cartridge Pack (80063) SM-C-804439	EA	1
12	5855-01-174-2462	Equipment Cover, Night Vision Sight (80063) SM-D-804553	EA	1

INTEGRAL COMPONENTS NIGHT VISION SIGHT SET, INFRARED AN/UAS-11 (CONT)

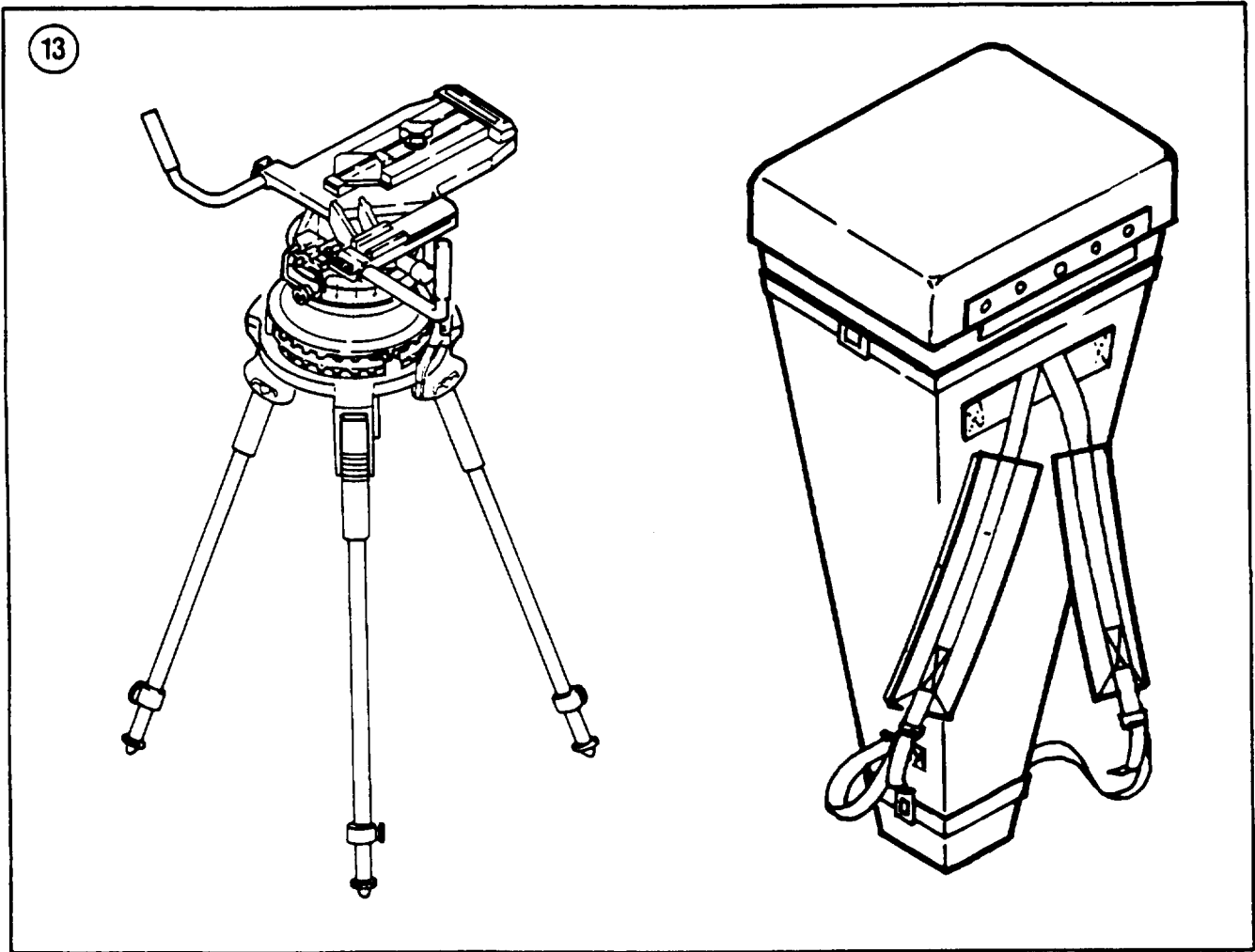

MS015527

(1) ILLUS NUMBER	(2) NATIONAL STOCK NUMBER	(3) DESCRIPTION FSCM AND PART NUMBER	(4) U/M	(5) QTY RQR
13	5855-01-108-9096	Tri pod, Ni ght Vi si on Si ght (80063) SM-C-806679	EA	1

**APPENDIX C  
ADDITIONAL AUTHORIZATION LIST**

---

**C-1 . SCOPE**

This appendix lists additional items you are authorized for the support of the AN/UAS-11.

**C-2. GENERAL**

This list identifies items that do not have to accompany the AN/UAS-11 and that do not have to be turned in with it. These items are all authorized to you by CTA, MTOE, TDA, or JTA.

**C-3. EXPLANATION OF LISTING**

National stock numbers, descriptions, and quantities are provided to help you identify and requests the additional items you require to support this equipment. The items are listed in alphabetical sequence by item name under the type document (i.e., CTA, MTOE, TDA, or JTA) which authorizes the item(s) to you.

**Section II. ADDITIONAL AUTHORIZATION LIST**

(1) NATIONAL STOCK NUMBER	(2) DESCRIPTION FSCM AND PART NUMBER	(3) U/M	(4) QTY AUTH
5855-01-030-8598	ARCTIC KIT (80063) SM-D-775084	EA	1



## APPENDIX D

### EXPENDABLE SUPPLIES AND MATERIALS LIST

---

#### Section I. INTRODUCTION

#### D-1 . SCOPE

This appendix lists expendable supplies and materials you will need to operate and maintain the AN/UAS-11. These items are authorized to you by CTA 50-970, Expendable Items (Except Medical, Class V, Repair Parts, and Heraldic Items).

#### D-2. EXPLANATION OF COLUMNS

a. Column (1) - Item Number. This number is assigned to the entry in the listing and is referenced in the narrative instructions to identify the material (e.g., "Item 2, Appendix D").

b. Column (2) - Level . This column identifies the lowest level of maintenance that requires the listed item.

C - Operator/Crew

c. Column (3) - National Stock Number. This is the National Stock number assigned to the item; use it to request or requisition the item.

d. Column (4) - Description. Indicates the Federal item name and, if required, a description to identify the item. The last line for each item indicates the Federal Supply Code for Manufacturers (FSCM) in parentheses followed by the part number.

e. Column (5) - Unit of Measure (U/M). Indicates the measure used in performing the actual maintenance function. This measure is expressed by a two-character alphabetical abbreviation (e.g., ea, in, pr). If the unit of measure differs from the unit of issue, requisition the lowest unit of issue that will satisfy your requirements.

**Section II. EXPENDABLE/DURABLE SUPPLIES AND MATERIALS LIST**

(1) ITEM NUMBER	(2) LEVEL	(3) NATIONAL STOCK NUMBER	(4) DESCRIPTION	(5) U/M
1	C	6135-00-930-0030	Battery, Dry Cell, BA-3030	PR
2	C	8320-00-299-8625	Pad, Cotton	LB
3	C	6530-00-786-4635	Pad, Heating, Chemi cal	EA
4	C	6810-00-201-0906	Alcohol, Denatured	PT
5	C	8010-01-229-7546	Paint, CARC, Camoufl age Green, 383 (80244), MI L-C-46168	PT
6	C	8010-00-935-7080	Coating, Primer (CARC) (81 349), MI L-P-23377, Type 1	KT

**INDEX**

Subject	Paragraph Number
<b>A</b>	
AN/GVS-5 stowage in APC .....	2-32
<b>B</b>	
Boresight Collimator optics cleaning procedure .....	2-23
Boresight Collimator stowage in APC .....	2-31
<b>C</b>	
Cable 2W2 stowage in APC .....	2-33
Collimating AN/GVS-5 to Night Sight .....	2-18
Connecting battery to traverse head assembly .....	2-15
Connecting rechargeable battery to Night Sight .....	2-16
Connecting vehicle power conditioner .....	2-14
Coolant cartridge pack and battery pack stowage in APC (curbside) .....	2-35
Coolant cartridge pack and battery pack stowage in APC (roadside) .....	2-36
<b>L</b>	
Leveling procedure .....	2-17
<b>N</b>	
Night Sight shutdown procedure .....	2-22
Night Sight stowage in APC .....	2-30
Night Sight troubleshooting procedures .....	3-2
<b>O</b>	
Operation .....	2-20
Operation in dusty or sandy areas .....	2-26
Operation in freezing temperatures .....	2-25
Operation in rainy or humid conditions .....	2-27
Operation in salt water areas .....	2-28
<b>P</b>	
Preventive maintenance checks and services (PMCS) .....	2-8

**INDEX (Cont)**

Subject	Paragraph Number
<b>R</b>	
Removal and replacement of azimuth scale lamp and level indicator lamp .....	3-9
Removal and replacement of Boresight Collimator battery .....	3-5
Removal and replacement of coolant cartridge .....	3-6
Removal and replacement of eyeshield .....	3-7
Removal and replacement of Night Sight battery .....	3-4
Removal and replacement of traverse head assembly battery .....	3-8
<b>S</b>	
Service to AN/UAS-11 Equipment Set .....	2-7
Setting up APC Mount Assembly .....	2-11
Setting up AN/GVS-5 to Night Sight .....	2-13
Setting up Night Sight on traverse head .....	2-12
Setting up Tripod .....	2-10
Standby operation .....	2-21
<b>T</b>	
Touchup painting .....	3-10
Transportation data .....	2-37
Tripod stowage in APC .....	2-34

By Order of the Secretary of the Army:

**JOHN A. WICKHAM, JR.**  
*General, United States Army*  
*Chief of Staff*

Official:

**MILDRED E. HEDBERG**  
*Brigadier General, United States Army*  
*The Adjutant General*

Distribution:

To be distributed in accordance with DA Form 12-32, Operator, Organizational, Direct Support and General Support Maintenance requirements for the Thermal Imagery Missile System.

RECOMMENDED CHANGES TO EQUIPMENT TECHNICAL PUBLICATIONS



THEN... JOT DOWN THE DOPE ABOUT IT ON THIS FORM. CAREFULLY TEAR IT OUT. FOLD IT AND DROP IT IN THE MAIL.

SOMETHING WRONG WITH THIS PUBLICATION?

FROM: (PRINT YOUR UNIT'S COMPLETE ADDRESS)

CDR, 1st Bn, 65th ADA  
ATTN: SP4 John Doe  
Key West, FL 33040

DATE SENT

14 January 1979

PUBLICATION NUMBER

TM 9-1430-550-34-1

PUBLICATION DATE

7 Sep 72

PUBLICATION TITLE

Unit of Radar Set  
AN/MPQ-50 Tested at the HFC

BE EXACT... PIN-POINT WHERE IT IS

PAGE NO	PARA-GRAPH	FIGURE NO	TABLE NO
9-19		9-5	
21-2	step 1C		21-2

IN THIS SPACE TELL WHAT IS WRONG AND WHAT SHOULD BE DONE ABOUT IT:

"B" Ready Relay K11 is shown with two #9 contacts. That contact which is wired to pin 8 of relay K16 should be changed to contact #10.

Reads: Multimeter B indicates 600 K ohms to 9000 K ohms.

Change to read: Multimeter B indicates 600 K ohms minimum.

Reason: Circuit being checked could measure infinity. Multimeter can read above 9000 K ohms and still be correct.

NOTE TO THE READER:

*Your comments will go directly to the writer responsible for this manual, and he will prepare the reply that is returned to you. To help him in his evaluation of your recommendations, please explain the reason for each of your recommendations, unless the reason is obvious.*

*All comments will be appreciated, and will be given immediate attention. Handwritten comments are acceptable.*

*For your convenience, blank "tear out" forms, preprinted, addressed, and ready to mail, are included in this manual.*

PRINTED NAME, GRADE OR TITLE, AND TELEPHONE NUMBER

SP4 John Doe, Autovon 222-222

SIGN HERE

RECOMMENDED CHANGES TO EQUIPMENT TECHNICAL PUBLICATIONS



THEN JOT DOWN THE DOPE ABOUT IT ON THIS FORM. CAREFULLY TEAR IT OUT. FOLD IT AND DROP IT IN THE MAIL.

SOMETHING WRONG WITH THIS PUBLICATION?

FROM (PRINT YOUR UNIT'S COMPLETE ADDRESS)

DATE SENT

PUBLICATION NUMBER

PUBLICATION DATE

PUBLICATION TITLE

BE EXACT. PIN-POINT WHERE IT IS

PAGE NO

PARA-GRAPH

FIGURE NO.

TABLE NO

IN THIS SPACE TELL WHAT IS WRONG AND WHAT SHOULD BE DONE ABOUT IT:

PRINTED NAME GRADE OR TITLE AND TELEPHONE NUMBER

SIGN HERE

DA FORM 2028-2  
1 JUL 79

PREVIOUS EDITIONS ARE OBSOLETE.

P.S.—IF YOUR OUTFIT WANTS TO KNOW ABOUT YOUR RECOMMENDATION MAKE A CARBON COPY OF THIS AND GIVE IT TO YOUR HEADQUARTERS

FILL IN YOUR  
UNIT'S ADDRESS

FOLD BACK

DEPARTMENT OF THE ARMY

\_\_\_\_\_  
\_\_\_\_\_

TEAR ALONG PERFORATED LINE

Commander  
U. S. Army Missile Command  
ATTN: AMSMI-LC-ME-P  
Redstone Arsenal, AL 35898-5238



# THE METRIC SYSTEM AND EQUIVALENTS

## WEIGHT MEASURE

1 Centimeter = 10 Millimeters = 0.01 Meters = 0.3937 Inches  
 1 Meter = 100 Centimeters = 1000 Millimeters = 39.37 Inches  
 1 Kilometer = 1000 Meters = 0.621 Miles

## WEIGHTS

1 Gram = 0.001 Kilograms = 1000 Milligrams = 0.035 Ounces  
 1 Kilogram = 1000 Grams = 2.2 lb.  
 1 Metric Ton = 1000 Kilograms = 1 Megagram = 1.1 Short Tons

## LIQUID MEASURE

1 Milliliter = 0.001 Liters = 0.0338 Fluid Ounces  
 1 Liter = 1000 Milliliters = 33.82 Fluid Ounces

## SQUARE MEASURE

1 Sq. Centimeter = 100 Sq. Millimeters = 0.155 Sq. Inches  
 1 Sq. Meter = 10,000 Sq. Centimeters = 10.76 Sq. Feet  
 1 Sq. Kilometer = 1,000,000 Sq. Meters = 0.386 Sq. Miles

## CUBIC MEASURE

1 Cu. Centimeter = 1000 Cu. Millimeters = 0.06 Cu. Inches  
 1 Cu. Meter = 1,000,000 Cu. Centimeters = 35.31 Cu. Feet

## TEMPERATURE

$5/9(^{\circ}\text{F} - 32) = ^{\circ}\text{C}$   
 212° Fahrenheit is equivalent to 100° Celsius  
 90° Fahrenheit is equivalent to 32.2° Celsius  
 32° Fahrenheit is equivalent to 0° Celsius  
 $9/5^{\circ}\text{C} + 32 = ^{\circ}\text{F}$

## APPROXIMATE CONVERSION FACTORS

TO CHANGE	TO	MULTIPLY BY
Inches	Centimeters	2.540
Feet	Meters	0.305
Yards	Meters	0.914
Miles	Kilometers	1.609
Square Inches	Square Centimeters	6.451
Square Feet	Square Meters	0.093
Square Yards	Square Meters	0.836
Square Miles	Square Kilometers	2.590
Acres	Square Hectometers	0.405
Cubic Feet	Cubic Meters	0.028
Cubic Yards	Cubic Meters	0.765
Fluid Ounces	Milliliters	29.573
its	Liters	0.473
arts	Liters	0.946
allons	Liters	3.785
Ounces	Grams	28.349
Pounds	Kilograms	0.454
Short Tons	Metric Tons	0.907
Pound-Feet	Newton-Meters	1.356
Pounds per Square Inch	Kilopascals	6.895
Miles per Gallon	Kilometers per Liter	0.425
Miles per Hour	Kilometers per Hour	1.609

TO CHANGE	TO	MULTIPLY BY
Centimeters	Inches	0.394
Meters	Feet	3.280
Meters	Yards	1.094
Kilometers	Miles	0.621
Square Centimeters	Square Inches	0.155
Square Meters	Square Feet	10.764
Square Meters	Square Yards	1.196
Square Kilometers	Square Miles	0.386
Square Hectometers	Acres	2.471
Cubic Meters	Cubic Feet	35.315
Cubic Meters	Cubic Yards	1.308
Milliliters	Fluid Ounces	0.034
Liters	Pints	2.113
Liters	Quarts	1.057
ers	Gallons	0.264
ms	Ounces	0.035
ograms	Pounds	2.205
Metric Tons	Short Tons	1.102
Newton-Meters	Pounds-Feet	0.738
Kilopascals	Pounds per Square Inch	0.145
ometers per Liter	Miles per Gallon	2.354
ometers per Hour	Miles per Hour	0.621

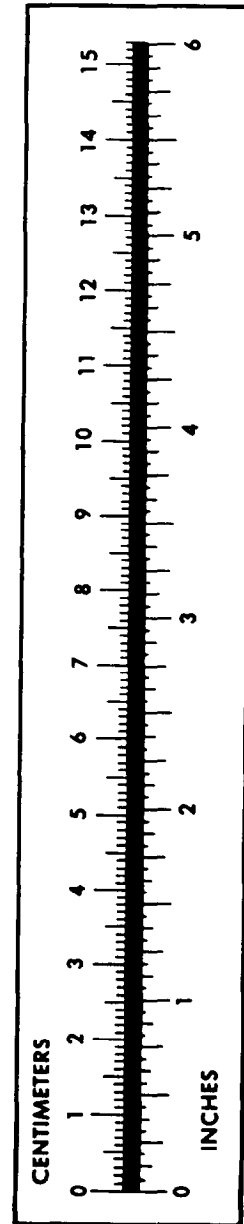

**PIN: 058923-002**